

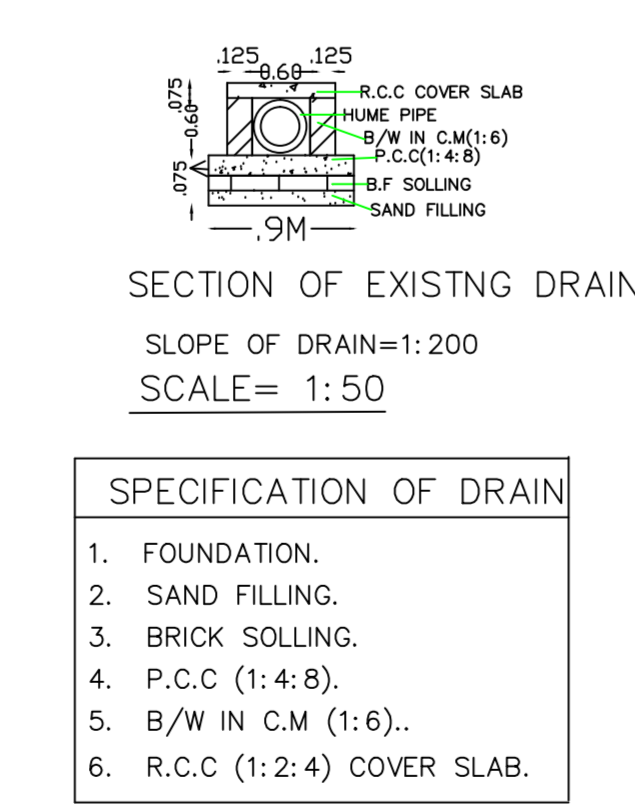

DATE	10-01-2021
SHEET NO	2
Proposed Basic Information	RDP/RP/000020
Owner Name	LOPOLA HOMES PVT LTD THROUGH ITS DIRECTOR UPI PRANCO NARAN GUPTA
Plot No	51
Plot No	541, 542, 544, 545, 546, 543, 540
Village Name	CHANDRAJI
Use	Residential
Scale	Residence/Bsq/Kompart

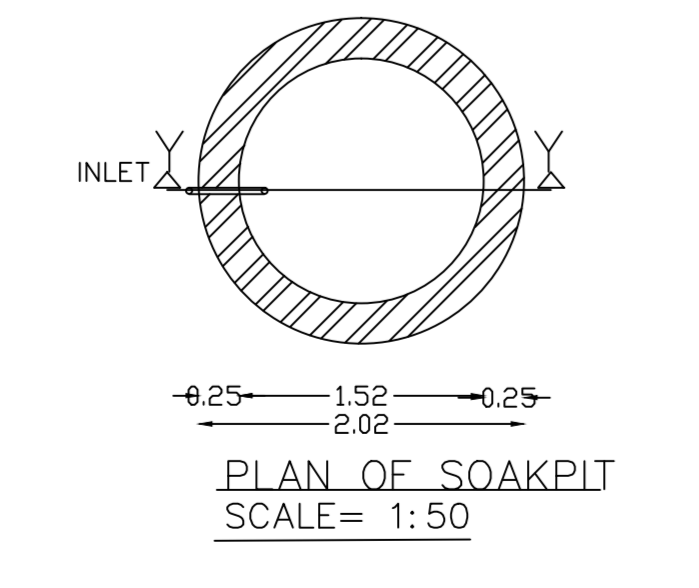

- SPECIFICATION OF DRAIN**
1. FOUNDATION.
  2. SAND FILLING.
  3. BRICK SOLING.
  4. P.C.C (1:4:8).
  5. B/W IN C.M (1:1.6).
  6. R.C.C (1:1.2:4) COVER SLAB.

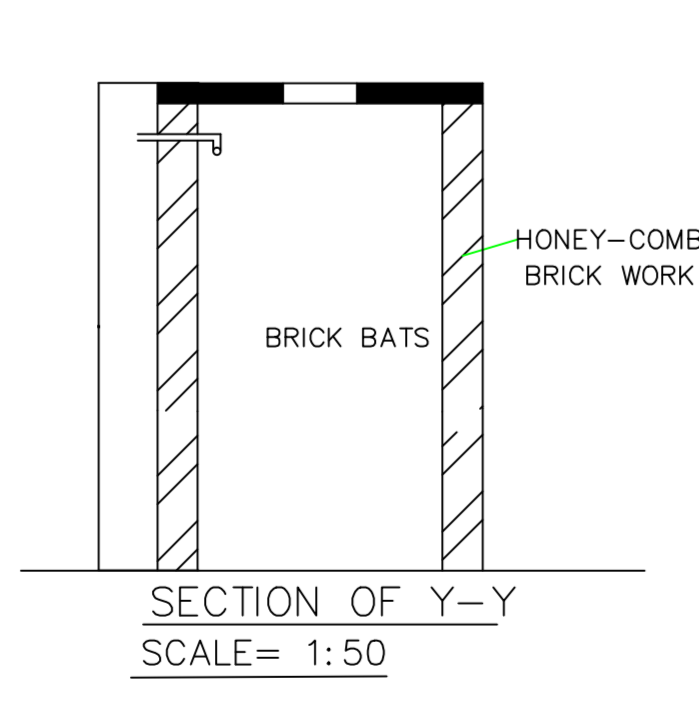
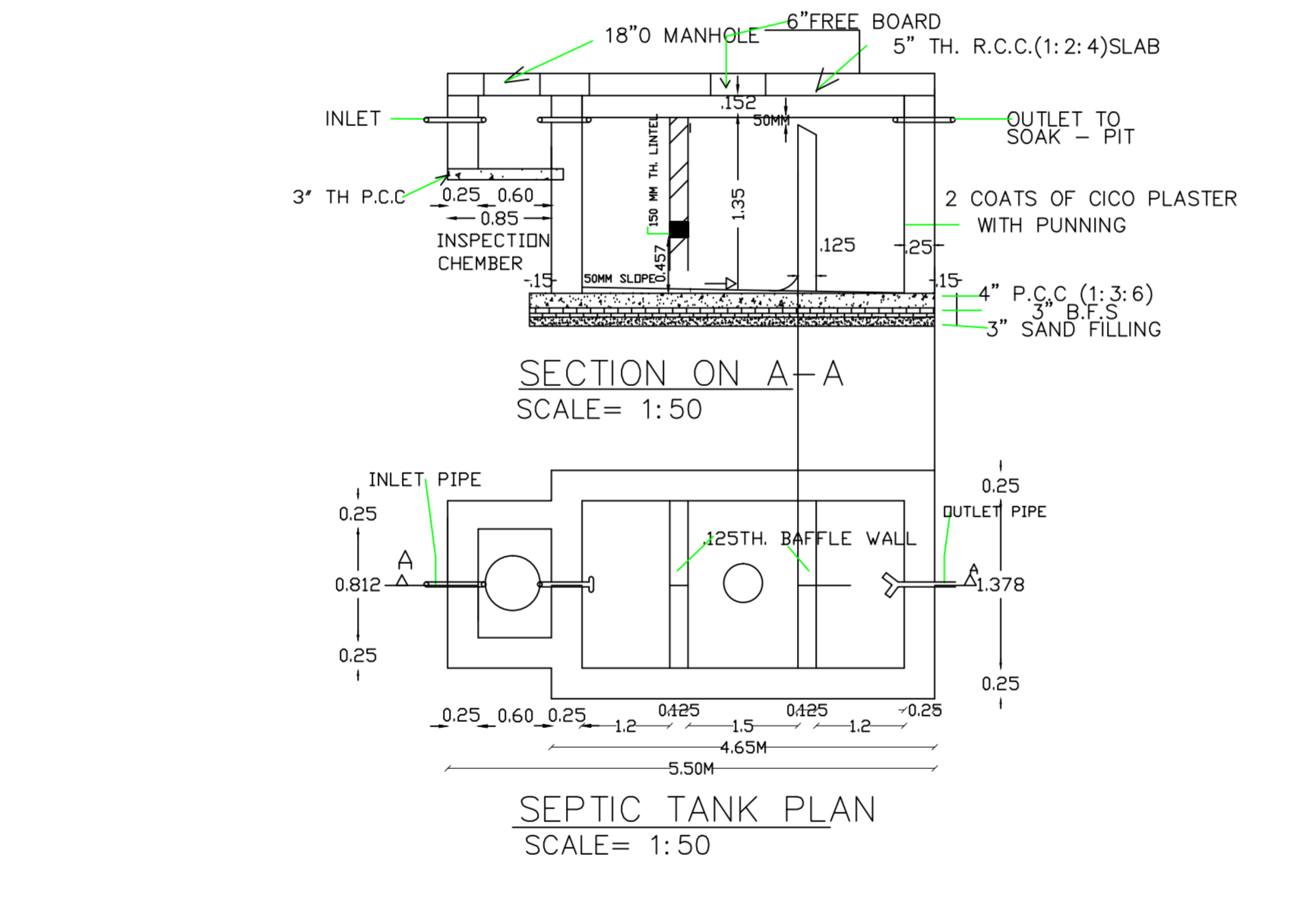
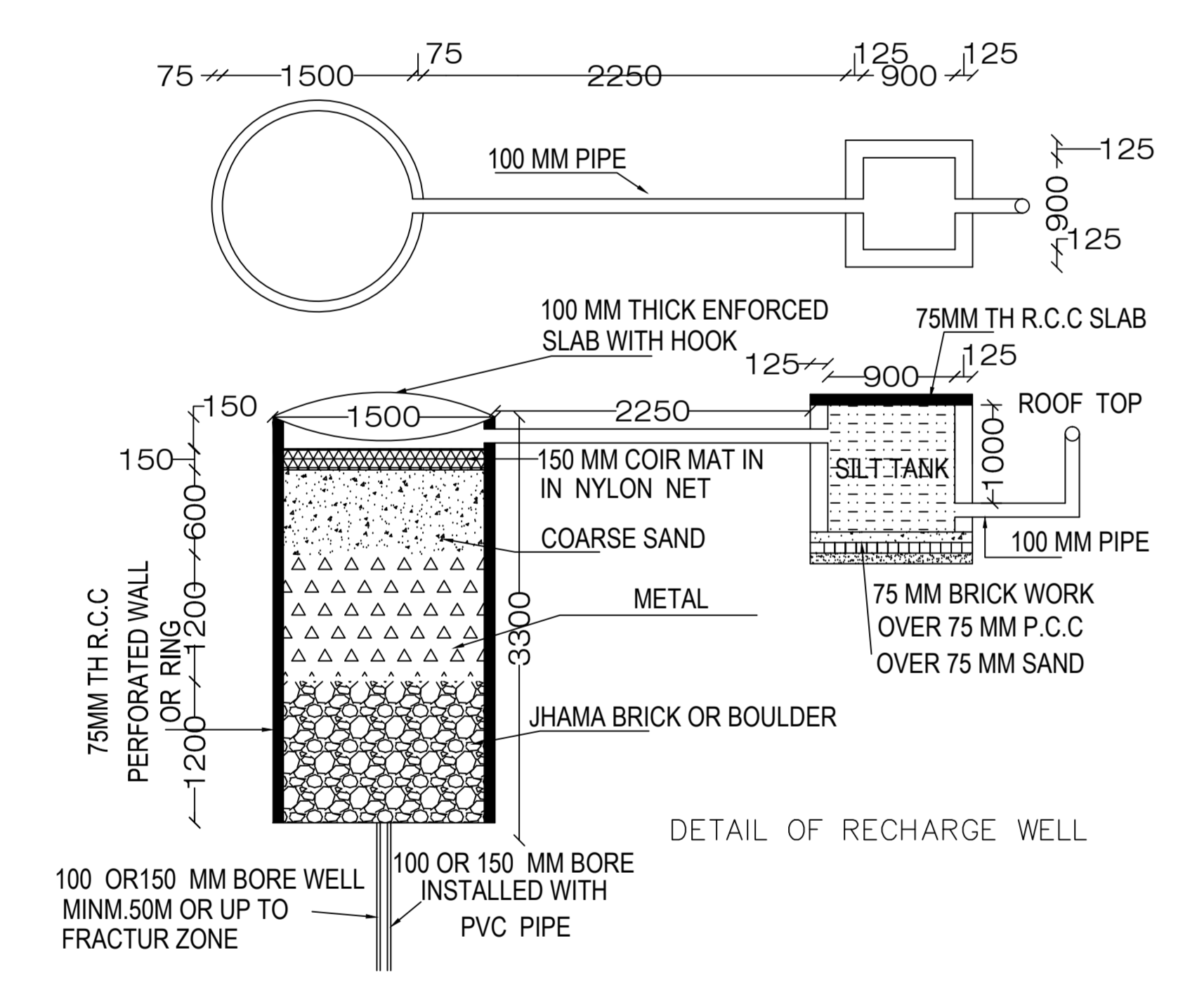
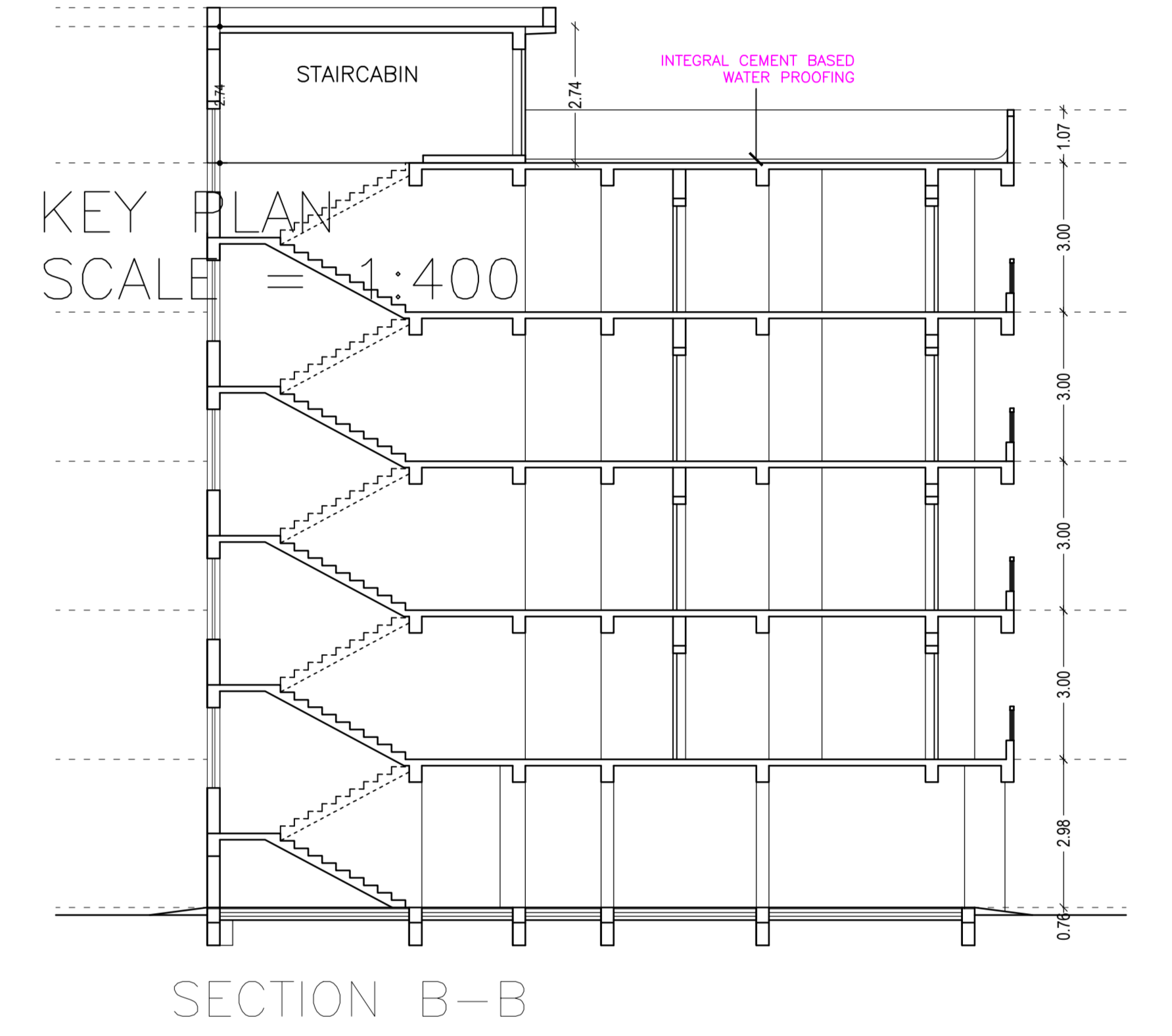
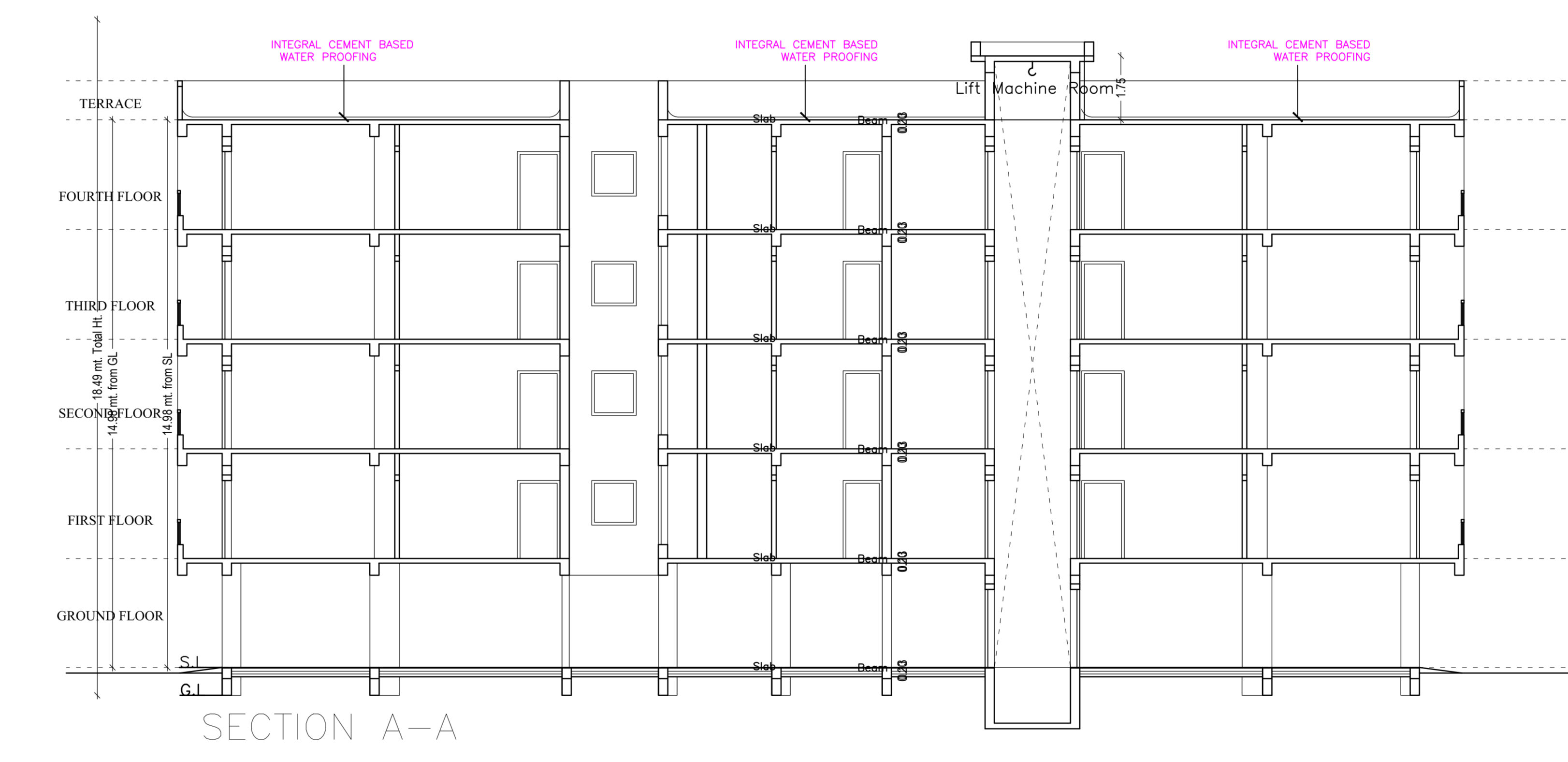
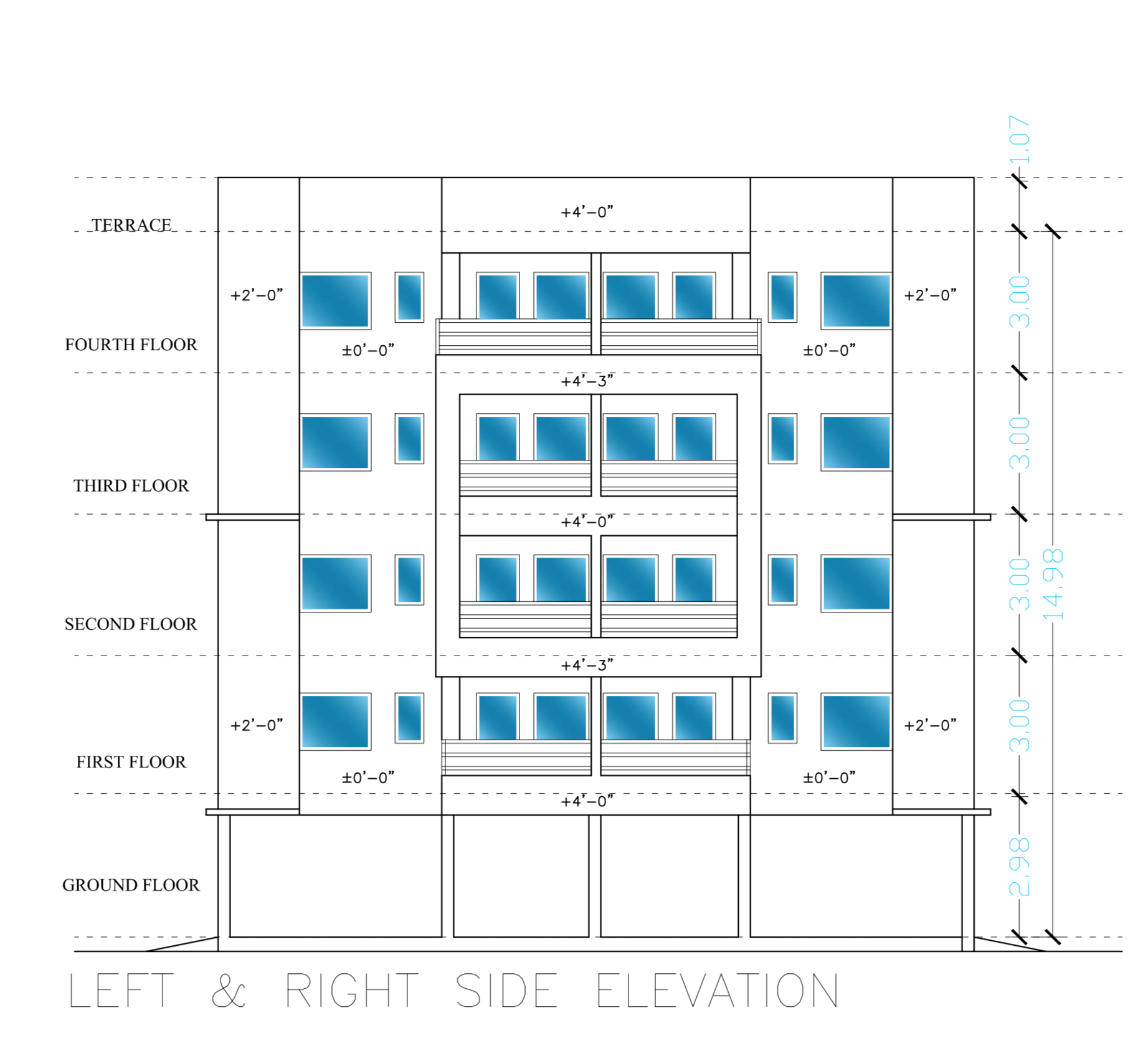
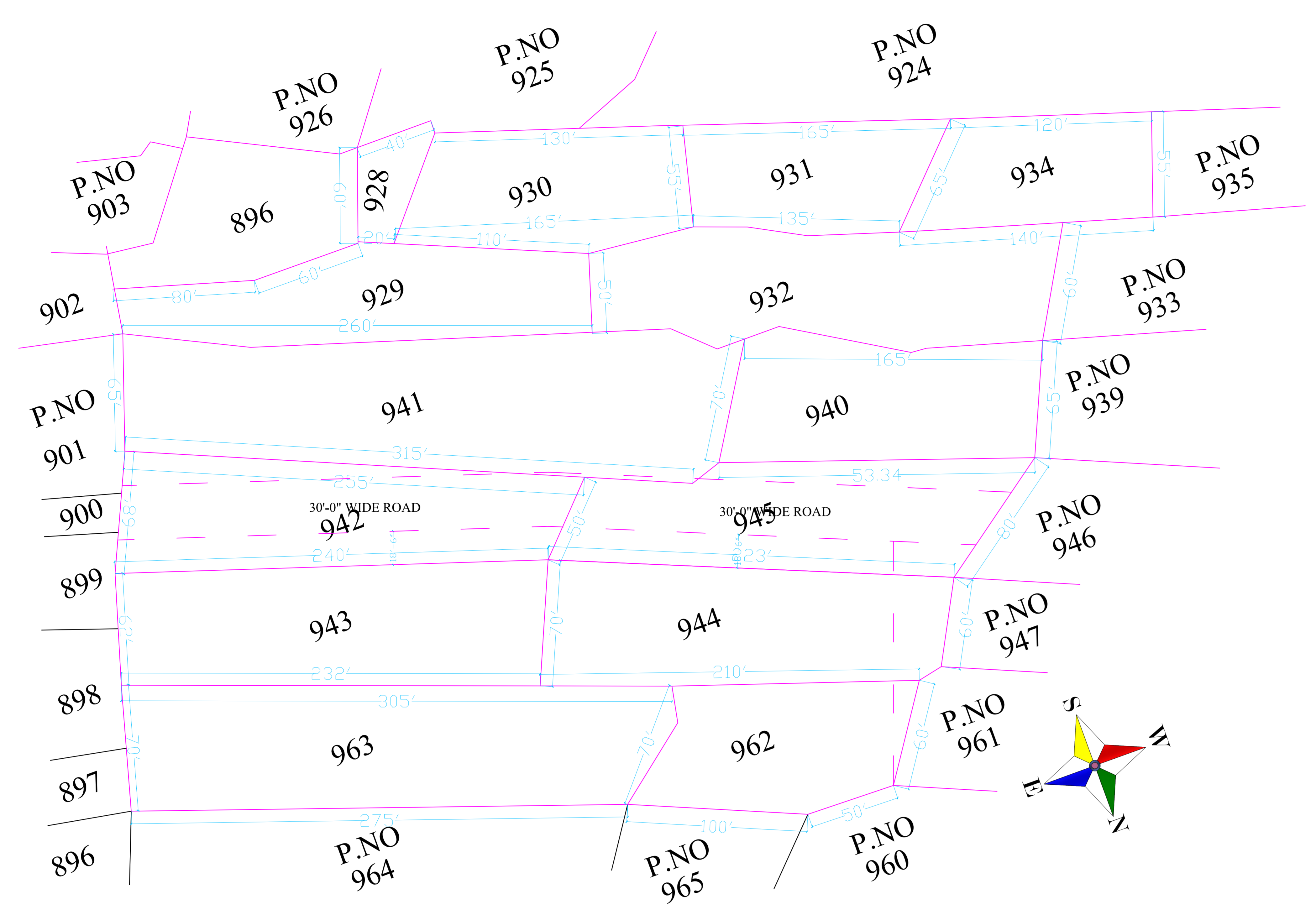
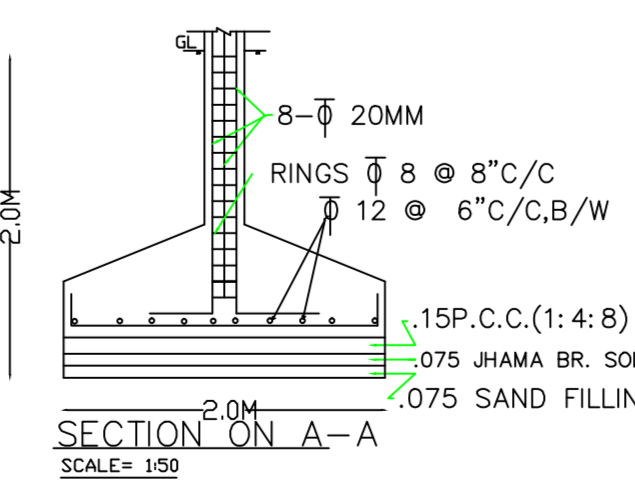

TOP NAME AND SIGNATURE	STRUCTURAL ENGINEER NAME AND SIGNATURE	BUILDER NAME AND SIGNATURE	DIGITAL SIGNATURE
RAJIV CHANDRA	RDP/RP/000020		