

UNIT/SHA Table for Building _M_S GAYATRI CONSTRUCTION (RESIDENTIAL APARTMENT)

FLOOR	Name	CHGK Type	Sub Area	Cover Area	No. of Units	No. of Rooms
FLOOR - 1	BEAT - 10	11.07	10.04	10.04	1	1
FLOOR - 2	BEAT - 10	11.07	10.04	10.04	1	1
FLOOR - 3	BEAT - 10	11.07	10.04	10.04	1	1
FLOOR - 4	BEAT - 10	11.07	10.04	10.04	1	1
FLOOR - 5	BEAT - 10	11.07	10.04	10.04	1	1
Total				40.16	5	5

Proposed File No.	REGD/REGD/2023
Owner Name	M/S MAA GAYATRI CONSTRUCTION THROUGH ITS DIRECTOR (1) - SRI SURAJ KUMAR SINGH (2) - SRI SURAJ KUMAR SINGH (3) - SRI SURAJ KUMAR SINGH (4) - SRI SURAJ KUMAR SINGH (5) - SRI SURAJ KUMAR SINGH
Plot No.	10.04
Block	RESIDENTIAL
Use	Residential
Sub Use	Residential (Apartment)

AREA STATEMENT RANGE	REVISIONS - 1.0.00
PROJECT TITLE	REVISION NO. 1.0.00
PROJECT LOCATION	Plot No. 10.04
LOCAL BODY	Local Body - Residential
LOCAL AUTHORITY	Local Authority - Residential
Project No.	Project No. 10.04
Project Type	Project Type - Residential
Project Location	Project Location - Residential
Project Area	Project Area - Residential
Project Date	Project Date - Residential
Project Status	Project Status - Residential
Project Owner	Project Owner - Residential
Project Designer	Project Designer - Residential
Project Engineer	Project Engineer - Residential
Project Architect	Project Architect - Residential
Project Surveyor	Project Surveyor - Residential
Project Consultant	Project Consultant - Residential
Project Contractor	Project Contractor - Residential
Project Subcontractor	Project Subcontractor - Residential
Project Material Supplier	Project Material Supplier - Residential
Project Laborer	Project Laborer - Residential
Project Inspector	Project Inspector - Residential
Project Approver	Project Approver - Residential
Project Signatory	Project Signatory - Residential
Project Seal	Project Seal - Residential
Project Stamp	Project Stamp - Residential
Project Registration No.	Project Registration No. - Residential
Project Registration Date	Project Registration Date - Residential
Project Registration Authority	Project Registration Authority - Residential
Project Registration Fee	Project Registration Fee - Residential
Project Registration Status	Project Registration Status - Residential
Project Registration Remarks	Project Registration Remarks - Residential
Project Registration Date	Project Registration Date - Residential
Project Registration Authority	Project Registration Authority - Residential
Project Registration Fee	Project Registration Fee - Residential
Project Registration Status	Project Registration Status - Residential
Project Registration Remarks	Project Registration Remarks - Residential

Color	Meaning
Green	Proposed Construction
Yellow	Existing Construction
Red	Existing to be demolished
Blue	Existing to be retained

Building Name	Building Use	Building Category	Building Structure
M/S MAA GAYATRI CONSTRUCTION (RESIDENTIAL APARTMENT)	Residential	Residential (Apartment)	Non-Highrise

Building Name	Building Use	Building Category	Building Structure
M/S MAA GAYATRI CONSTRUCTION (RESIDENTIAL APARTMENT)	Residential	Residential (Apartment)	Non-Highrise

Vehicle Type	No.	Area	No.	Area
Two Wheel Car	12	18.00	12	18.00
Four Wheel Car	2	20.00	2	20.00
Total	14	38.00	14	38.00

Building Name	Building Use	Building Category	Building Structure
M/S MAA GAYATRI CONSTRUCTION (RESIDENTIAL APARTMENT)	Residential	Residential (Apartment)	Non-Highrise

Building Name	Building Use	Building Category	Building Structure
M/S MAA GAYATRI CONSTRUCTION (RESIDENTIAL APARTMENT)	Residential	Residential (Apartment)	Non-Highrise

Building Name	Building Use	Building Category	Building Structure
M/S MAA GAYATRI CONSTRUCTION (RESIDENTIAL APARTMENT)	Residential	Residential (Apartment)	Non-Highrise

Building Name	Building Use	Building Category	Building Structure
M/S MAA GAYATRI CONSTRUCTION (RESIDENTIAL APARTMENT)	Residential	Residential (Apartment)	Non-Highrise

Building Name	Building Use	Building Category	Building Structure
M/S MAA GAYATRI CONSTRUCTION (RESIDENTIAL APARTMENT)	Residential	Residential (Apartment)	Non-Highrise

Building Name	Building Use	Building Category	Building Structure
M/S MAA GAYATRI CONSTRUCTION (RESIDENTIAL APARTMENT)	Residential	Residential (Apartment)	Non-Highrise

Building Name	Building Use	Building Category	Building Structure
M/S MAA GAYATRI CONSTRUCTION (RESIDENTIAL APARTMENT)	Residential	Residential (Apartment)	Non-Highrise

Building Name	Building Use	Building Category	Building Structure
M/S MAA GAYATRI CONSTRUCTION (RESIDENTIAL APARTMENT)	Residential	Residential (Apartment)	Non-Highrise

Building Name	Building Use	Building Category	Building Structure
M/S MAA GAYATRI CONSTRUCTION (RESIDENTIAL APARTMENT)	Residential	Residential (Apartment)	Non-Highrise

Building Name	Building Use	Building Category	Building Structure
M/S MAA GAYATRI CONSTRUCTION (RESIDENTIAL APARTMENT)	Residential	Residential (Apartment)	Non-Highrise

Building Name	Building Use	Building Category	Building Structure
M/S MAA GAYATRI CONSTRUCTION (RESIDENTIAL APARTMENT)	Residential	Residential (Apartment)	Non-Highrise

Building Name	Building Use	Building Category	Building Structure
M/S MAA GAYATRI CONSTRUCTION (RESIDENTIAL APARTMENT)	Residential	Residential (Apartment)	Non-Highrise

Building Name	Building Use	Building Category	Building Structure
M/S MAA GAYATRI CONSTRUCTION (RESIDENTIAL APARTMENT)	Residential	Residential (Apartment)	Non-Highrise

Building Name	Building Use	Building Category	Building Structure
M/S MAA GAYATRI CONSTRUCTION (RESIDENTIAL APARTMENT)	Residential	Residential (Apartment)	Non-Highrise

Building Name	Building Use	Building Category	Building Structure
M/S MAA GAYATRI CONSTRUCTION (RESIDENTIAL APARTMENT)	Residential	Residential (Apartment)	Non-Highrise

Building Name	Building Use	Building Category	Building Structure
M/S MAA GAYATRI CONSTRUCTION (RESIDENTIAL APARTMENT)	Residential	Residential (Apartment)	Non-Highrise

Building Name	Building Use	Building Category	Building Structure
M/S MAA GAYATRI CONSTRUCTION (RESIDENTIAL APARTMENT)	Residential	Residential (Apartment)	Non-Highrise

Building Name	Building Use	Building Category	Building Structure
M/S MAA GAYATRI CONSTRUCTION (RESIDENTIAL APARTMENT)	Residential	Residential (Apartment)	Non-Highrise

Building Name	Building Use	Building Category	Building Structure
M/S MAA GAYATRI CONSTRUCTION (RESIDENTIAL APARTMENT)	Residential	Residential (Apartment)	Non-Highrise

Building Name	Building Use	Building Category	Building Structure
M/S MAA GAYATRI CONSTRUCTION (RESIDENTIAL APARTMENT)	Residential	Residential (Apartment)	Non-Highrise

Building Name	Building Use	Building Category	Building Structure
M/S MAA GAYATRI CONSTRUCTION (RESIDENTIAL APARTMENT)	Residential	Residential (Apartment)	Non-Highrise

Building Name	Building Use	Building Category	Building Structure
M/S MAA GAYATRI CONSTRUCTION (RESIDENTIAL APARTMENT)	Residential	Residential (Apartment)	Non-Highrise

Building Name	Building Use	Building Category	Building Structure
M/S MAA GAYATRI CONSTRUCTION (RESIDENTIAL APARTMENT)	Residential	Residential (Apartment)	Non-Highrise

Building Name	Building Use	Building Category	Building Structure
M/S MAA GAYATRI CONSTRUCTION (RESIDENTIAL APARTMENT)	Residential	Residential (Apartment)	Non-Highrise

Building Name	Building Use	Building Category	Building Structure
M/S MAA GAYATRI CONSTRUCTION (RESIDENTIAL APARTMENT)	Residential	Residential (Apartment)	Non-Highrise

Building Name	Building Use	Building Category	Building Structure
M/S MAA GAYATRI CONSTRUCTION (RESIDENTIAL APARTMENT)	Residential	Residential (Apartment)	Non-Highrise

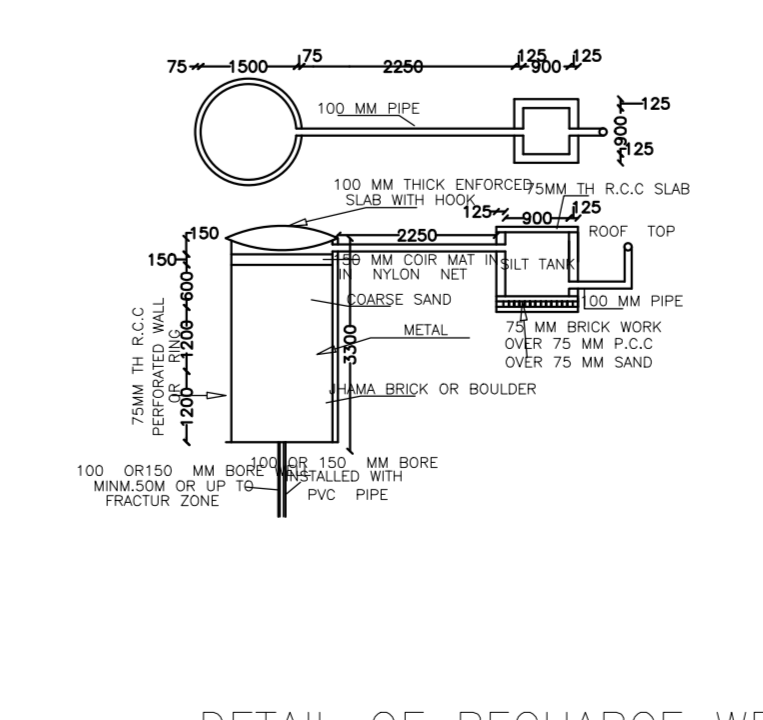
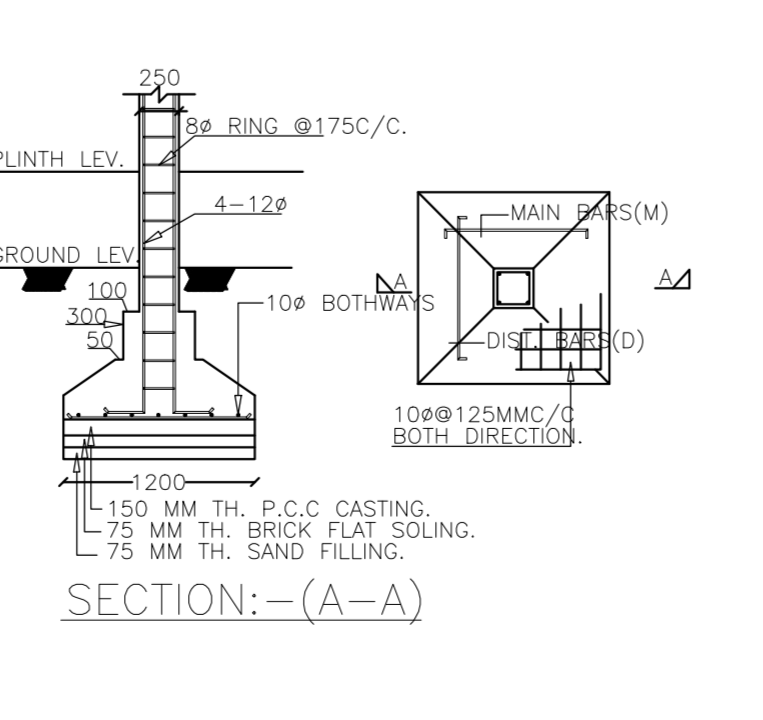
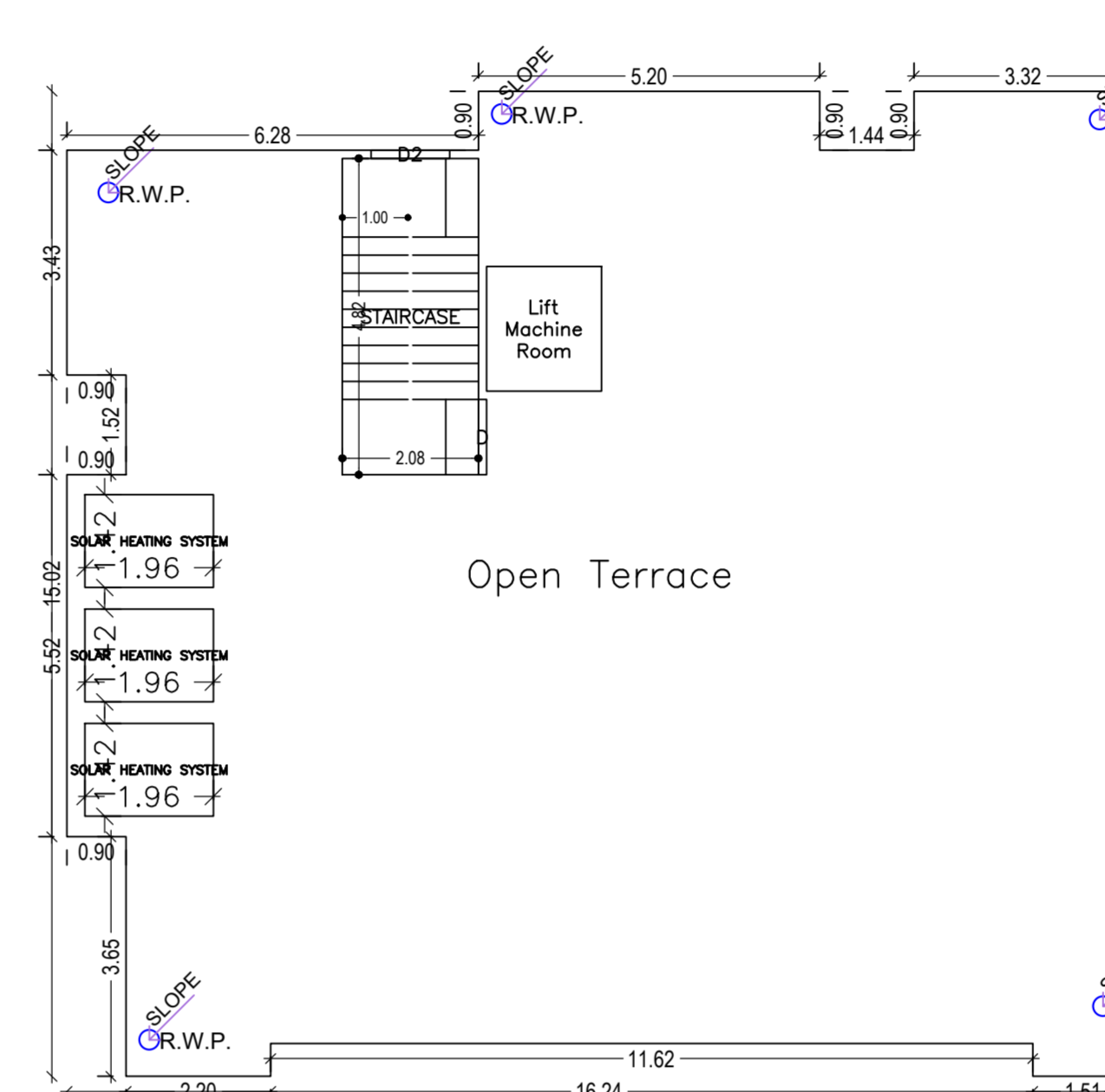
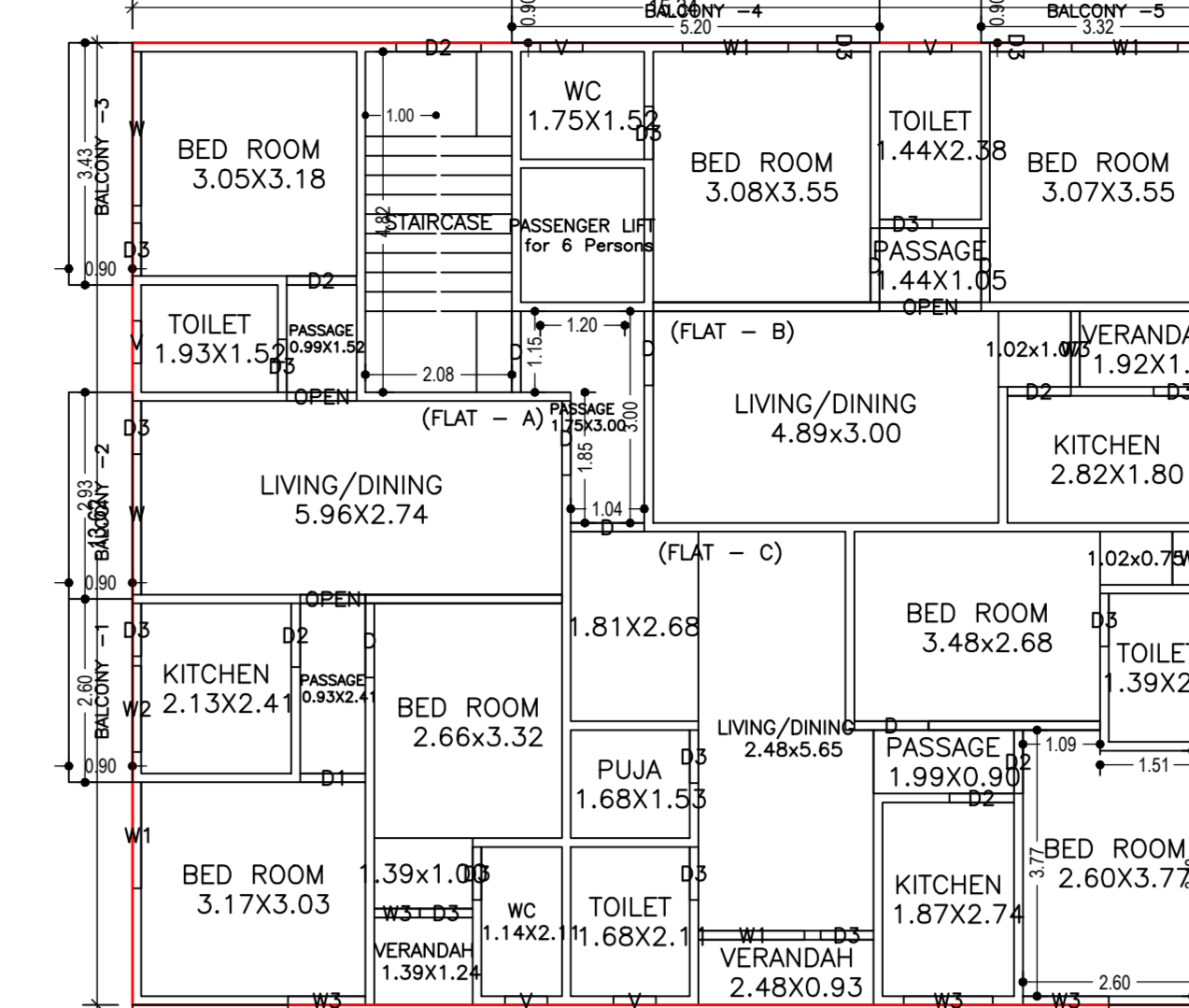
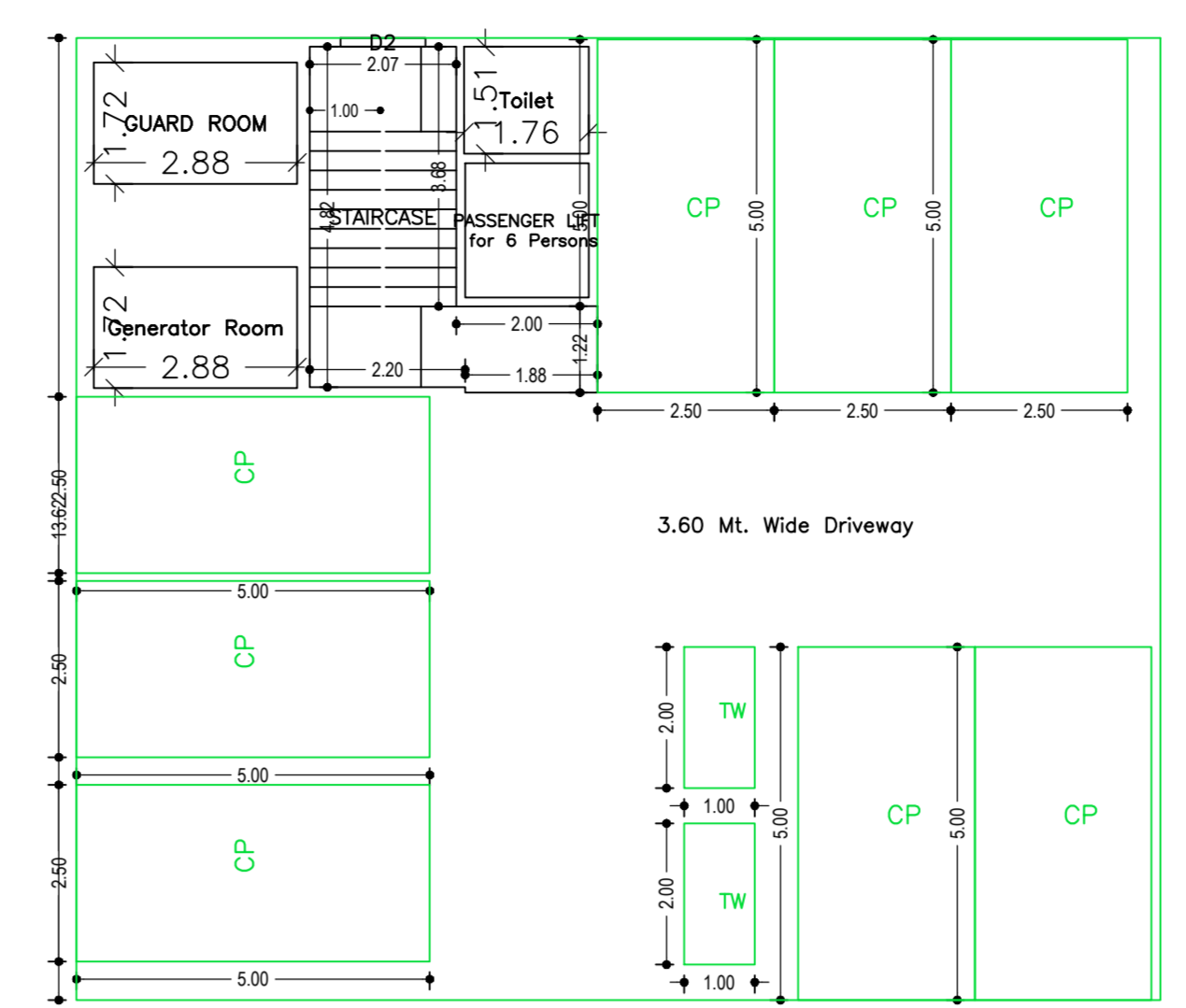
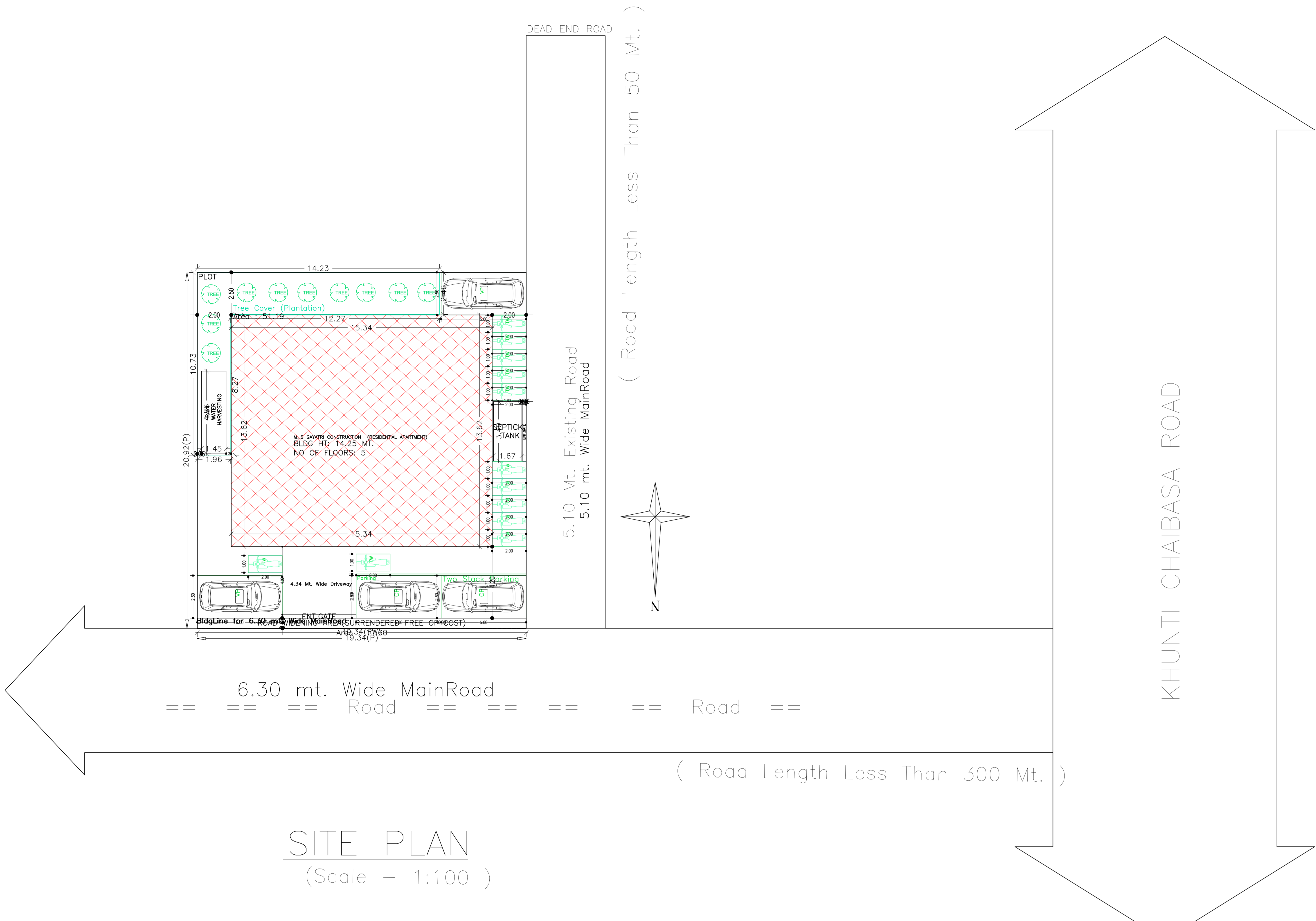

STRUCTURAL SAFETY CERTIFICATION
This is to certify that the structural design of this building shall be as per I.S.-1893 and I.S.-4326 - 1993 to make the same earthquake resistant.

TYPICAL FLOOR PLAN	AREA	TOTAL AREA
1.00 x 1.00 x 1.00	1.00	1.00
1.00 x 1.00 x 1.00	1.00	2.00
1.00 x 1.00 x 1.00	1.00	3.00
1.00 x 1.00 x 1.00	1.00	4.00
1.00 x 1.00 x 1.00	1.00	5.00
1.00 x 1.00 x 1.00	1.00	6.00
1.00 x 1.00 x 1.00	1.00	7.00
1.00 x 1.00 x 1.00	1.00	8.00
1.00 x 1.00 x 1.00	1.00	9.00
1.00 x 1.00 x 1.00	1.00	10.00
1.00 x 1.00 x 1.00	1.00	11.00
1.00 x 1.00 x 1.00	1.00	12.00
1.00 x 1.00 x 1.00	1.00	13.00
1.00 x 1.00 x 1.00	1.00	14.00
1.00 x 1.00 x 1.00	1.00	15.00
1.00 x 1.00 x 1.00	1.00	16.00
1.00 x 1.00 x 1.00	1.00	17.00
1.00 x 1.00 x 1.00	1.00	18.00
1.00 x 1.00 x 1.00	1.00	19.00
1.00 x 1.00 x 1.00	1.00	20.00
1.00 x 1.00 x 1.00	1.00	21.00
1.00 x 1.00 x 1.00	1.00	22.00
1.00 x 1.00 x 1.00	1.00	23.00
1.00 x 1.00 x 1.00	1.00	24.00
1.00 x 1.00 x 1.00	1.00	25.00
1.00 x 1.00 x 1.00	1.00	26.00
1.00 x 1.00 x 1.00	1.00	27.00
1.00 x 1.00 x 1.00	1.00	28.00
1.00 x 1.00 x 1.00	1.00	29.00
1.00 x 1.00 x 1.00	1.00	30.00
1.00 x 1.00 x 1.00	1.00	31.00
1.00 x 1.00 x 1.00	1.00	32.00
1.00 x 1.00 x 1.00	1.00	33.00
1.00 x 1.00 x 1.00	1.00	34.00
1.00 x 1.00 x 1.00	1.00	35.00
1.00 x 1.00 x 1.00	1.00	36.00
1.00 x 1.00 x 1.00	1.00	37.00
1.00 x 1.00 x 1.00	1.00	38.00
1.00 x 1.00 x 1.00	1.00	39.00
1.00 x 1.00 x 1.00	1.00	40.00
1.00 x 1.00 x 1.00	1.00	41.00
1.00 x 1.00 x 1.00	1.00	42.00
1.00 x 1.00 x 1.00	1.00	43.00
1.00 x 1.00 x 1.00	1.00	44.00
1.00 x 1.00 x 1.00	1.00	45.00
1.00 x 1.00 x 1.00	1.00	46.00
1.00 x 1.00 x 1.00	1.00	47.00
1.00 x 1.00 x 1.00	1.00	48.00
1.00 x 1.00 x 1.00	1.00	49.00
1.00 x 1.00 x 1.00	1.00	50.00
1.00 x 1.00 x 1.00	1.00	51.00
1.00 x 1.00 x 1.00	1.00	52.00
1.00 x 1.00 x 1.00	1.00	53.00
1.00 x 1.00 x 1.00	1.00	54.00
1.00 x 1.00 x 1.00	1.00	55.00
1.00 x 1.00 x 1.00	1.00	56.00
1.00 x 1.00 x 1.00	1.00	57.00
1.00 x 1.00 x 1.00	1.00	58.00
1.00 x 1.00 x 1.00	1.00	59.00
1.00 x 1.00 x 1.00	1.00	60.00
1.00 x 1.00 x 1.00	1.00	61.00
1.00 x 1.00 x 1.00	1.00	62.00
1.00 x 1.00 x 1.00	1.00	63.00
1.00 x 1.00 x 1.00	1.00	64.00
1.00 x 1.00 x 1.00	1.00	65.00
1.00 x 1.00 x 1.00	1.00	66.00
1.00 x 1.00 x 1.00	1.00	67.00
1.00 x 1.00 x 1.00	1.00	68.00
1.00 x 1.00 x 1.00	1.00	69.00
1.00 x 1.00 x 1.00	1.00	70.00
1.00 x 1.00 x 1.00	1.00	71.00
1.00 x 1.00 x 1.00	1.00	72.00
1.00 x 1.00 x 1.00	1.00	73.00
1.00 x 1.00 x 1.00	1.00	74.00
1.00 x 1.00 x 1.00	1.00	75.00
1.00 x 1.00 x 1.00	1.00	76.00
1.00 x 1.00 x 1.00	1.00	77.00
1.00 x 1.00 x 1.00	1.00	78.00
1.00 x 1.00 x 1.00	1.00	79.00
1.00 x 1.00 x 1.00	1.00	80.00
1.00 x 1.00 x 1.00	1.00	81.00
1.00 x 1.00 x 1.00	1.00	82.00
1.00 x 1.00 x 1.00	1.00	83.00
1.00 x 1.00 x 1.00	1.00	84.00
1.00 x 1.00 x 1.00	1.00	85.00
1.00 x 1.00 x 1.00	1.00	86.00
1.00 x 1.00 x 1.00	1.00	87.00
1.00 x 1.00 x 1.00	1.00	88.00
1.00 x 1.00 x 1.00	1.00	89.00
1.00 x 1.00 x 1.00	1.00	90.00
1.00 x 1.00 x 1.00	1.00	91.00
1.00 x 1.00 x 1.00	1.00	92.00
1.00 x 1.00 x 1.00	1.00	