

Proposed Basic Information	Project No.	100@125MM/C
Owner Name	MR. NARESH DEVIL SHIRMA	100@125MM/C
Plot No.	51	
Site No.	1455	
Use	Residential	
Scale	Residence/Bsp/Comment	

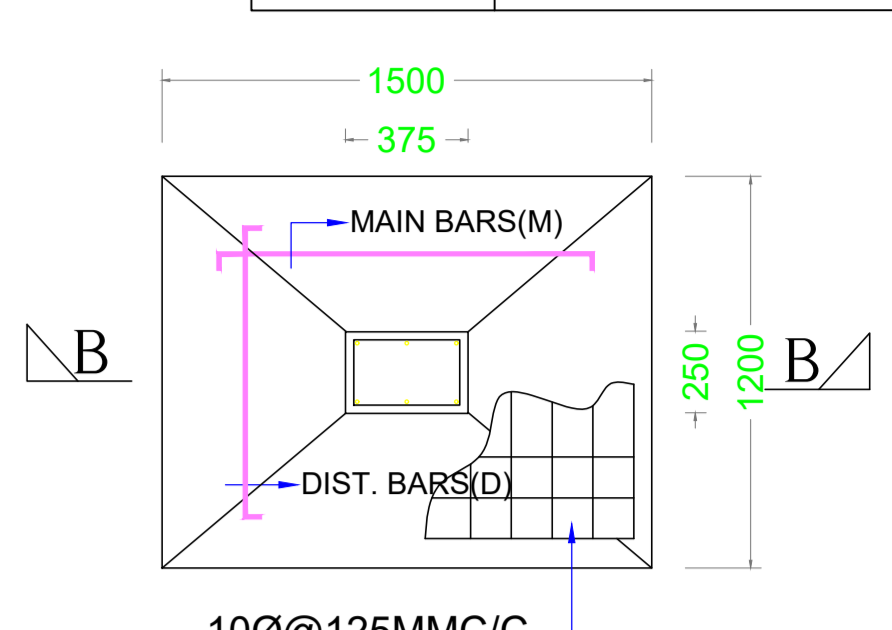

SECTION-(B-B)

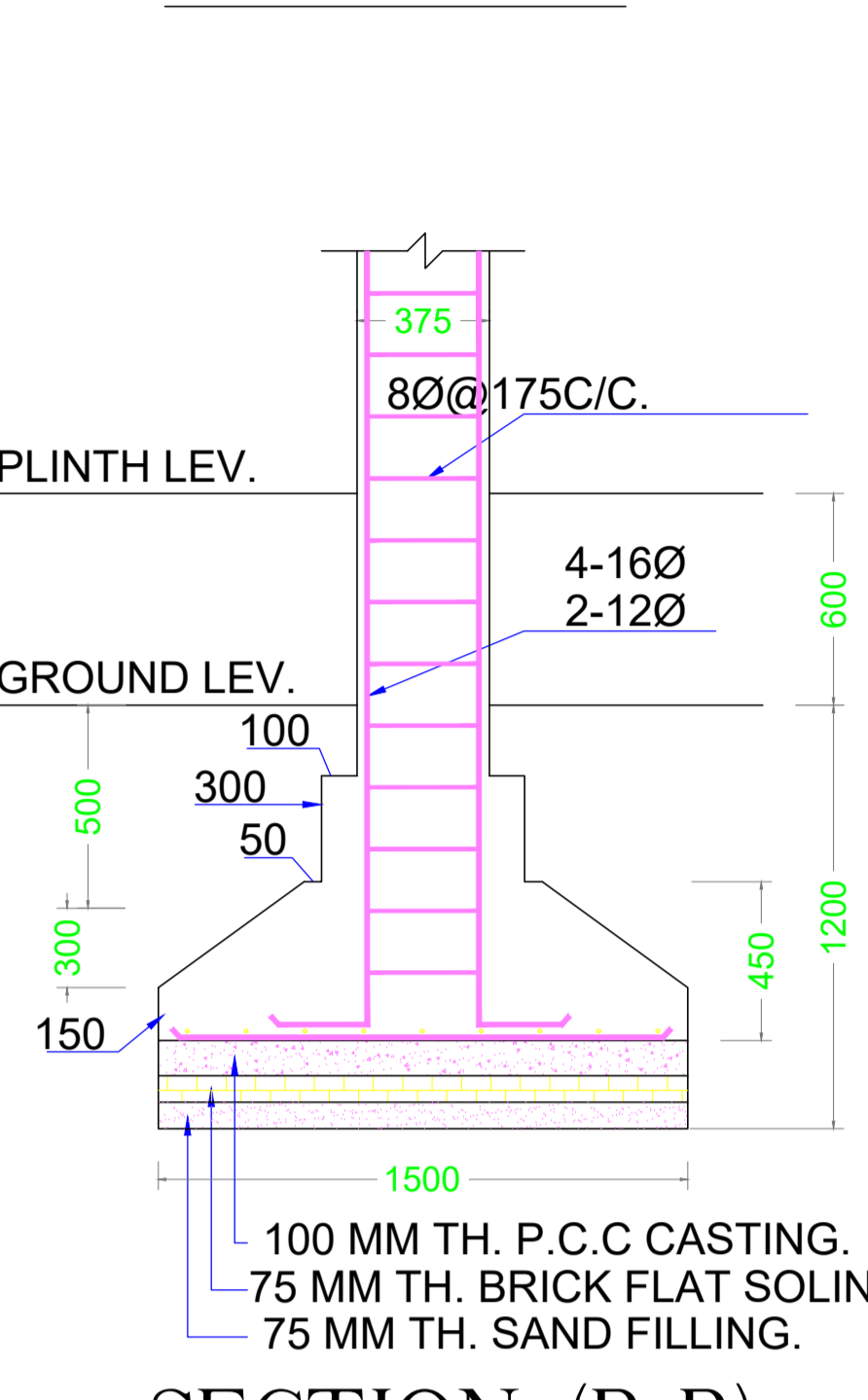

SECTION-(B-B)

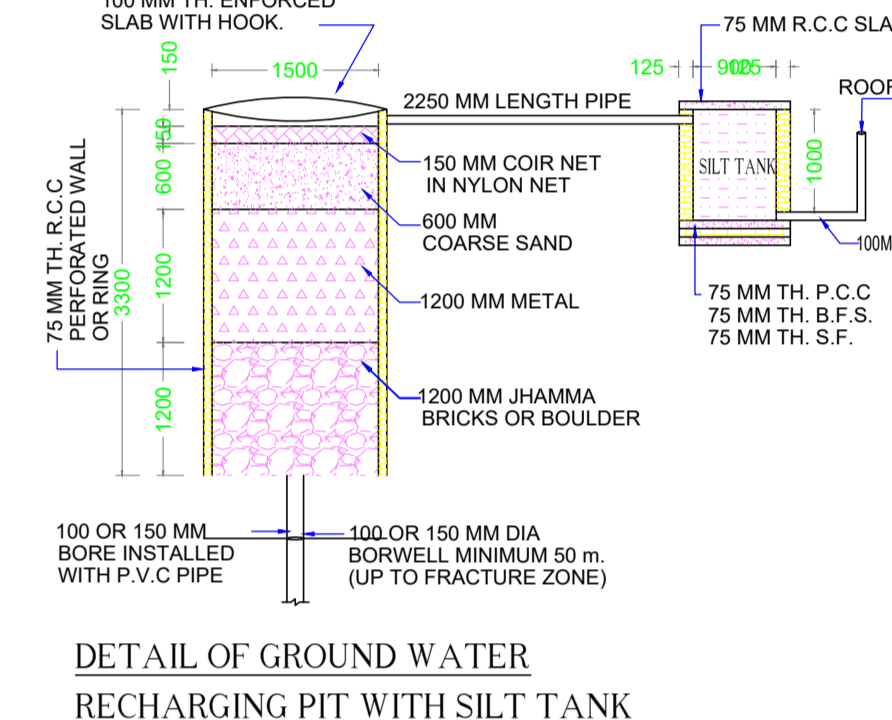

SECTION OF DRAIN

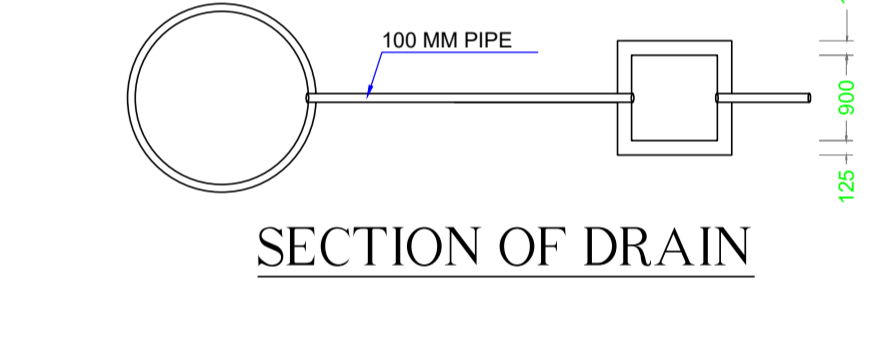

SOAK PIT PLAN

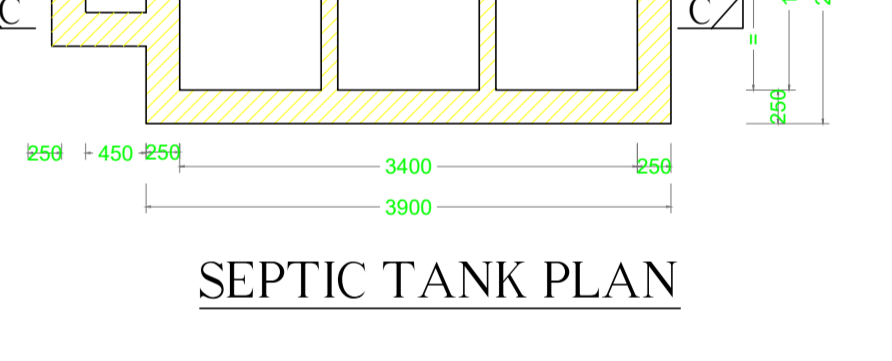

SEPTIC TANK PLAN

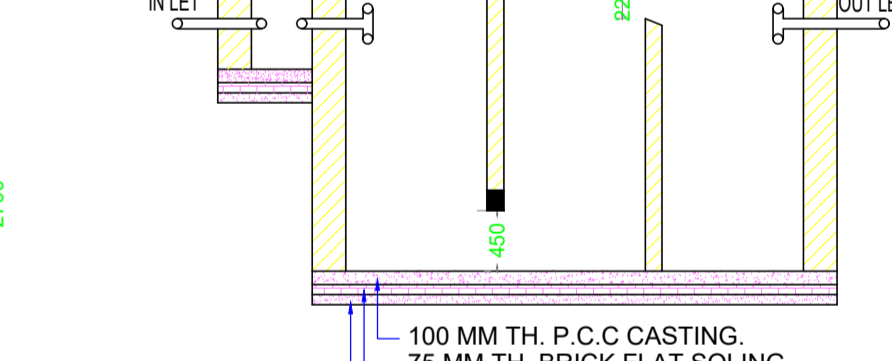

SECTION-(D-D)

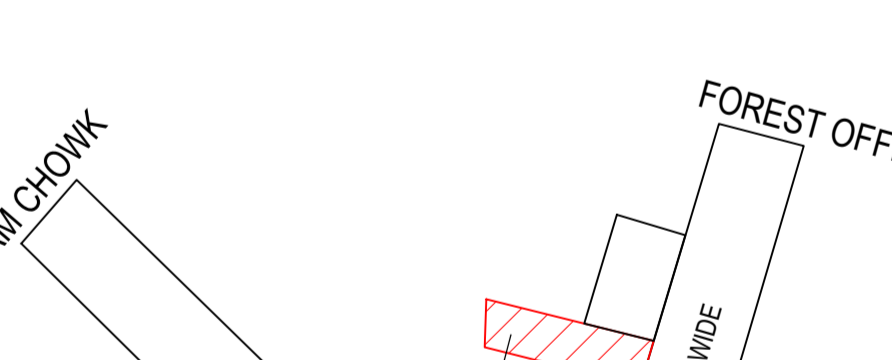

SECTION-(C-C)

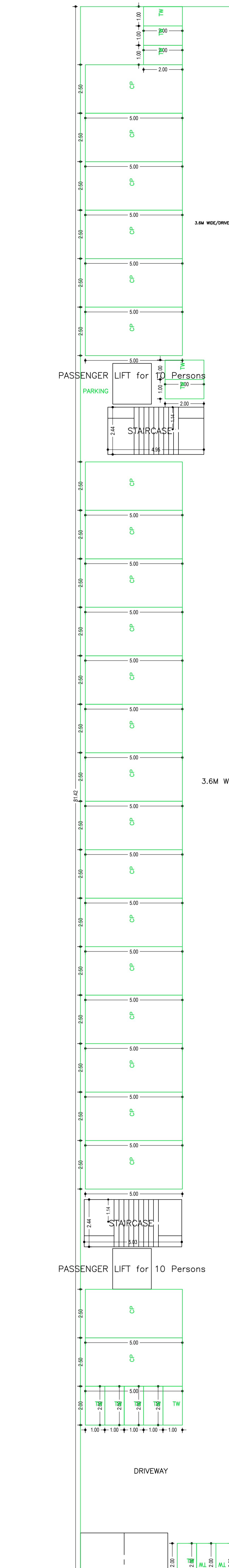
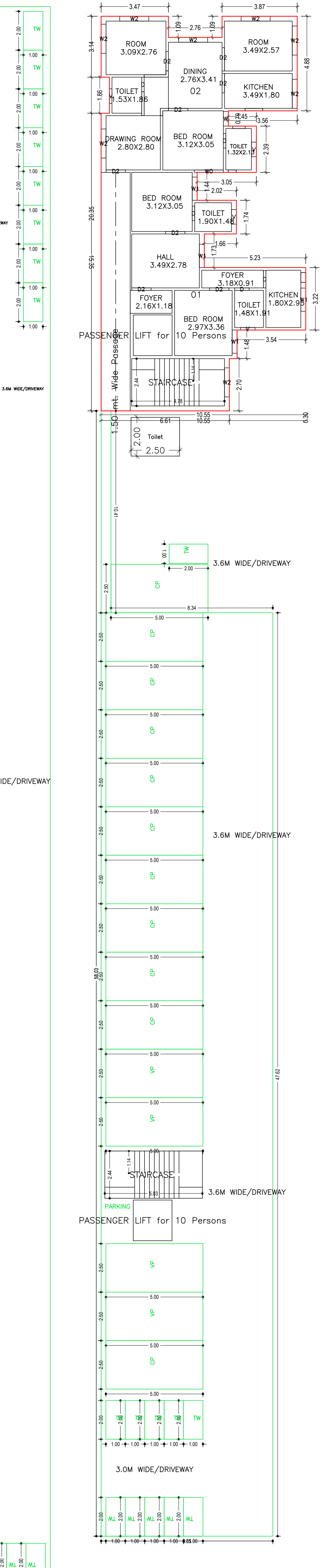
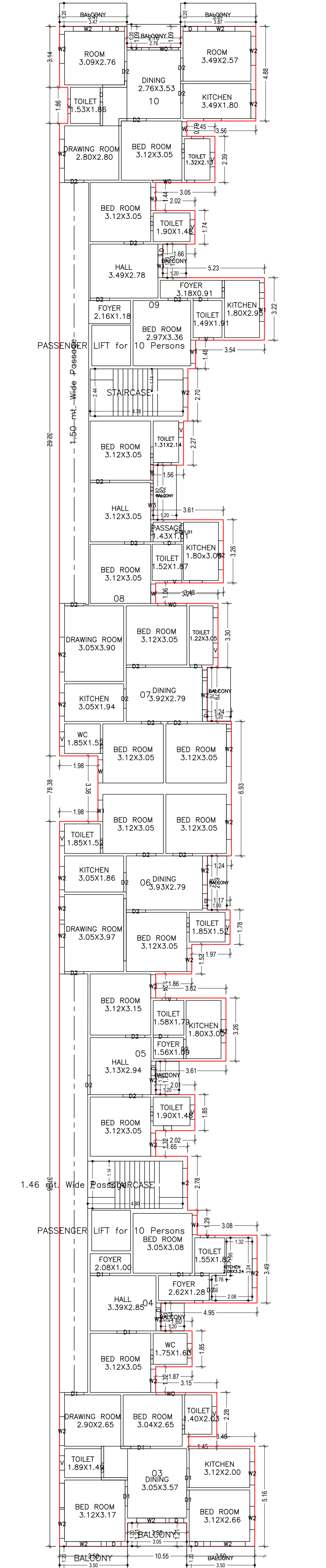
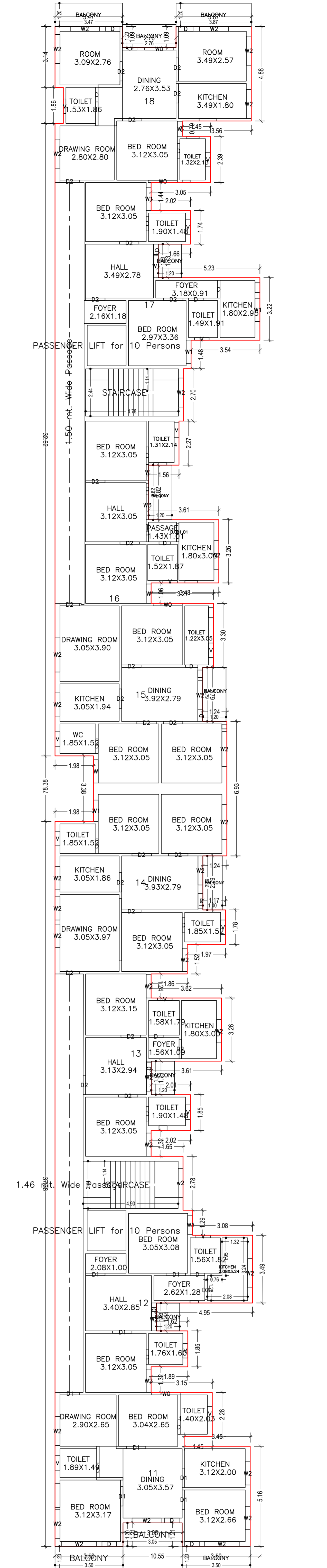
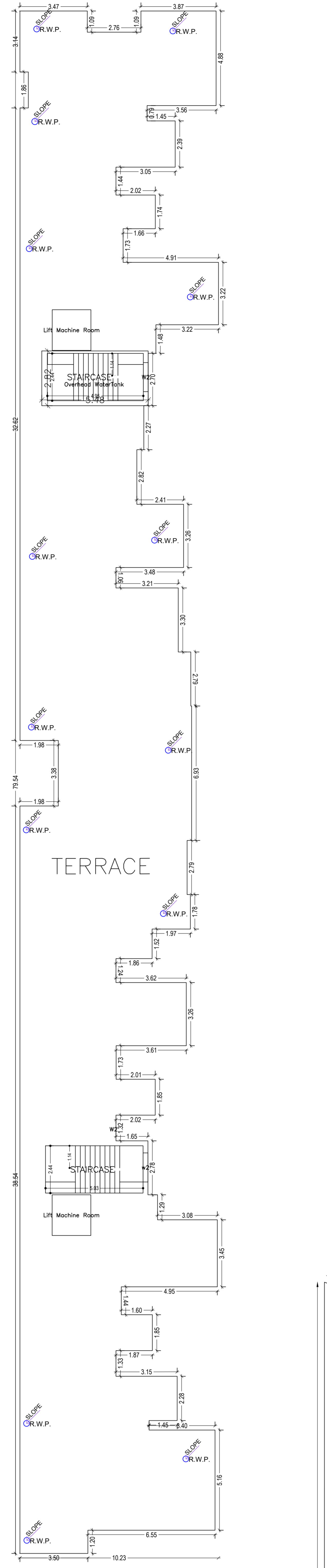
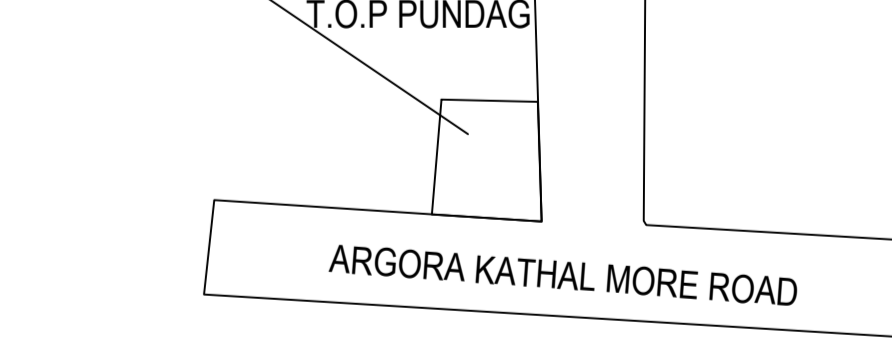
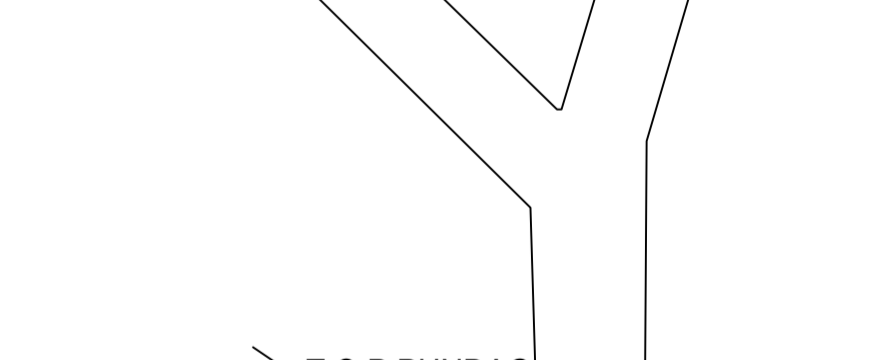

13.00 mt. long 1.85 mt. High 4.50 mt. Wide Natural Slope

Building -A (A1)

Floor	Total Area (Sq.Mt)	Carpet Area (Sq.Mt)	Proposed Area (Sq.Mt)	Area in TAC (Sq.Mt)	Total Area (Sq.Mt)	Carpet Area (Sq.Mt)	Total Area (Sq.Mt)
Basement	364.50	21.96	1215.35	2017.17	364.50	21.96	364.50
Ground	118.11	118.11	118.11	118.11	118.11	118.11	118.11
Typical	118.11	118.11	118.11	118.11	118.11	118.11	118.11
Roof	118.11	118.11	118.11	118.11	118.11	118.11	118.11
Total	718.83	466.29	2636.92	4552.50	718.83	466.29	718.83

SCHEDULE OF DOOR

DOOR NAME	NO.	LENGTH	HEIGHT	NO.
D	01	2.10	2.10	01
D	02	2.10	2.10	01
D	03	2.10	2.10	01
D	04	2.10	2.10	01
D	05	2.10	2.10	01

Balcony Calculations Table

FLOOR	NO.	AREA	TOTAL AREA
TYPICAL 2, 3 & 4 FLOOR	11	118.11	118.11
Basement	12	118.11	118.11
Ground	13	118.11	118.11
Roof	14	118.11	118.11
Total		466.29	466.29

UnRIBA Table for Building -A (A1)

FLOOR	Name	UNRIBA Type	UNRIBA Area	Carpet Area	No. of Rooms	No. of Toilets
Basement	11	FLAT	118.11	46.63	2	2
Basement	12	FLAT	118.11	46.63	2	2
Basement	13	FLAT	118.11	46.63	2	2
Basement	14	FLAT	118.11	46.63	2	2
Basement	15	FLAT	118.11	46.63	2	2
Basement	16	FLAT	118.11	46.63	2	2
Basement	17	FLAT	118.11	46.63	2	2
Basement	18	FLAT	118.11	46.63	2	2
Basement	19	FLAT	118.11	46.63	2	2
Basement	20	FLAT	118.11	46.63	2	2
Basement	21	FLAT	118.11	46.63	2	2
Basement	22	FLAT	118.11	46.63	2	2
Basement	23	FLAT	118.11	46.63	2	2
Basement	24	FLAT	118.11	46.63	2	2
Basement	25	FLAT	118.11	46.63	2	2
Basement	26	FLAT	118.11	46.63	2	2
Basement	27	FLAT	118.11	46.63	2	2
Basement	28	FLAT	118.11	46.63	2	2
Basement	29	FLAT	118.11	46.63	2	2
Basement	30	FLAT	118.11	46.63	2	2
Basement	31	FLAT	118.11	46.63	2	2
Basement	32	FLAT	118.11	46.63	2	2
Basement	33	FLAT	118.11	46.63	2	2
Basement	34	FLAT	118.11	46.63	2	2
Basement	35	FLAT	118.11	46.63	2	2
Basement	36	FLAT	118.11	46.63	2	2
Basement	37	FLAT	118.11	46.63	2	2
Basement	38	FLAT	118.11	46.63	2	2
Basement	39	FLAT	118.11	46.63	2	2
Basement	40	FLAT	118.11	46.63	2	2
Basement	41	FLAT	118.11	46.63	2	2
Basement	42	FLAT	118.11	46.63	2	2
Basement	43	FLAT	118.11	46.63	2	2
Basement	44	FLAT	118.11	46.63	2	2
Basement	45	FLAT	118.11	46.63	2	2
Basement	46	FLAT	118.11	46.63	2	2
Basement	47	FLAT	118.11	46.63	2	2
Basement	48	FLAT	118.11	46.63	2	2
Basement	49	FLAT	118.11	46.63	2	2
Basement	50	FLAT	118.11	46.63	2	2
Basement	51	FLAT	118.11	46.63	2	2
Basement	52	FLAT	118.11	46.63	2	2
Basement	53	FLAT	118.11	46.63	2	2
Basement	54	FLAT	118.11	46.63	2	2
Basement	55	FLAT	118.11	46.63	2	2
Basement	56	FLAT	118.11	46.63	2	2
Basement	57	FLAT	118.11	46.63	2	2
Basement	58	FLAT	118.11	46.63	2	2
Basement	59	FLAT	118.11	46.63	2	2
Basement	60	FLAT	118.11	46.63	2	2
Basement	61	FLAT	118.11	46.63	2	2
Basement	62	FLAT	118.11	46.63	2	2
Basement	63	FLAT	118.11	46.63	2	2
Basement	64	FLAT	118.11	46.63	2	2
Basement	65	FLAT	118.11	46.63	2	2
Basement	66	FLAT	118.11	46.63	2	2
Basement	67	FLAT	118.11	46.63	2	2
Basement	68	FLAT	118.11	46.63	2	2
Basement	69	FLAT	118.11	46.63	2	2
Basement	70	FLAT	118.11	46.63	2	2
Basement	71	FLAT	118.11	46.63	2	2
Basement	72	FLAT	118.11	46.63	2	2
Basement	73	FLAT	118.11	46.63	2	2
Basement	74	FLAT	118.11	46.63	2	2
Basement	75	FLAT	118.11	46.63	2	2
Basement	76	FLAT	118.11	46.63	2	2
Basement	77	FLAT	118.11	46.63	2	2
Basement	78	FLAT	118.11	46.63	2	2
Basement	79	FLAT	118.11	46.63	2	2
Basement	80	FLAT	118.11	46.63	2	2
Basement	81	FLAT	118.11	46.63	2	2
Basement	82	FLAT	118.11	46.63	2	2
Basement	83	FLAT	118.11	46.63	2	2
Basement	84	FLAT	118.11	46.63	2	2
Basement	85	FLAT	118.11	46.63	2	2
Basement	86	FLAT	118.11	46.63	2	2
Basement	87	FLAT	118.11	46.63	2	2
Basement	88	FLAT	118.11	46.63	2	2
Basement	89	FLAT	118.11	46.63	2	2
Basement	90	FLAT	118.11	46.63	2	2
Basement	91	FLAT	118.11	46.63	2	2
Basement	92	FLAT	118.11	46.63	2	2
Basement	93	FLAT	118.11	46.63	2	2
Basement	94	FLAT	118.11	46.63	2	2
Basement	95	FLAT	118.11	46.63	2	2
Basement	96	FLAT	118.11	46.63	2	2
Basement	97	FLAT	118.11	46.63	2	2
Basement	98	FLAT	118.11	46.63	2	2
Basement	99	FLAT	118.11	46.63	2	2
Basement	100	FLAT	118.11	46.63	2	2

TITLE NAME AND SIGNATURE: NARESH DEVIL SHIRMA
STRUCTURAL ENGINEER NAME AND SIGNATURE: NARESH DEVIL SHIRMA
BUILDER NAME AND SIGNATURE: NARESH DEVIL SHIRMA
DIGITAL SIGNATURE: NARESH DEVIL SHIRMA

DATE	04-01-2024
SHEET NO	3
Proposed Basic Information	
Proposer File No.	2023/03/0001
Owner Name	SHRI SHIBU DEVJI SHIRMA G/11, WARD NO. 4, DEVJI
Plot No.	51
Plot No.	1456
City/Town	Gulbarga
Use	Residential
Sub Use	Residential-Flat/Apartment

TEP NAME AND SIGNATURE	STRUCTURAL ENGINEER NAME AND SIGNATURE	BUILDER NAME AND SIGNATURE	DIGITAL SIGNATURE
DHARMENDRA KUMAR MNP/CA/001/2017			