

Proposed Basic Information	
Propose File No.	RMC/SP/16/03/0004
Owner Name	Gagan Mehrotra
Plot No.	53
Plot No.	710
Uplift Name	TSP/DANA
Use	Commercial
Sub Use	Res/Comm-Bldg

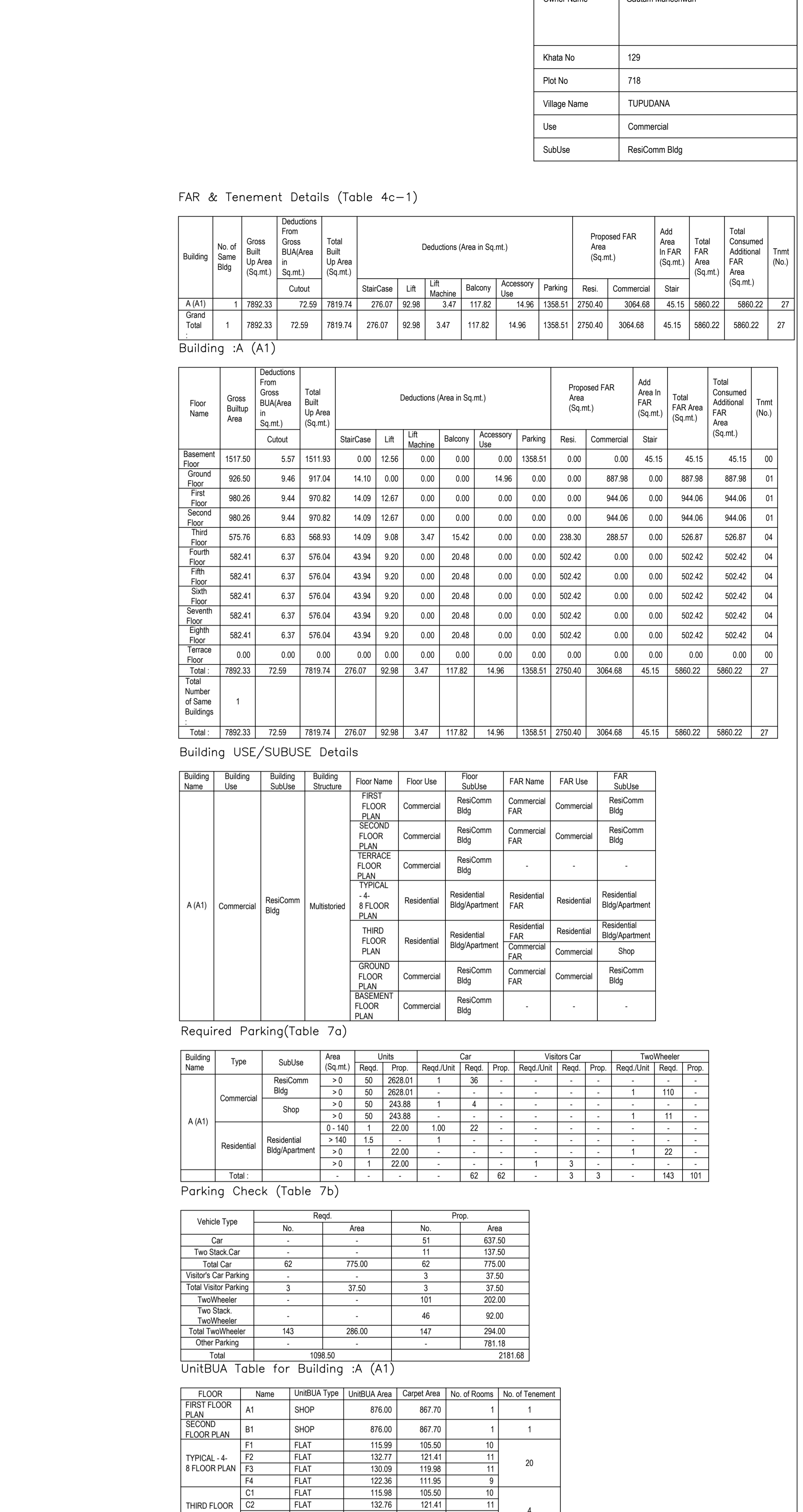
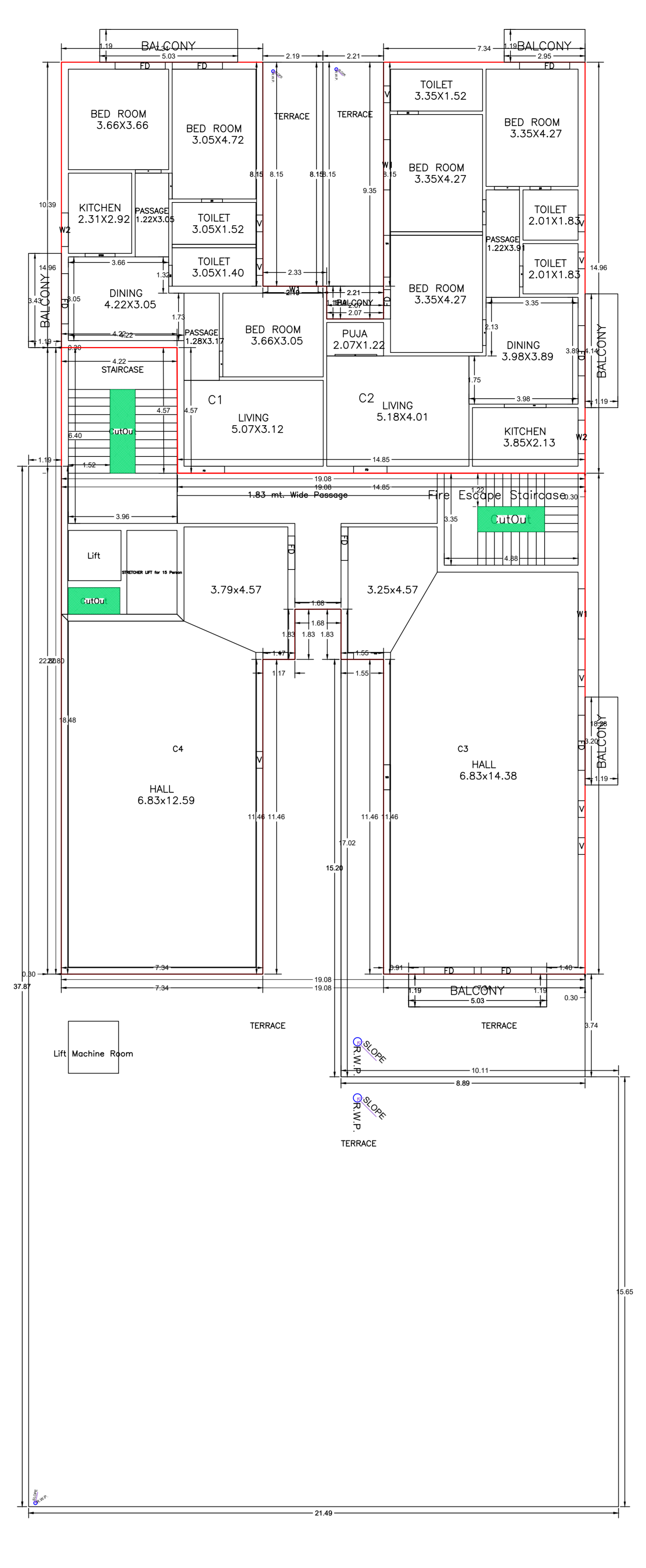
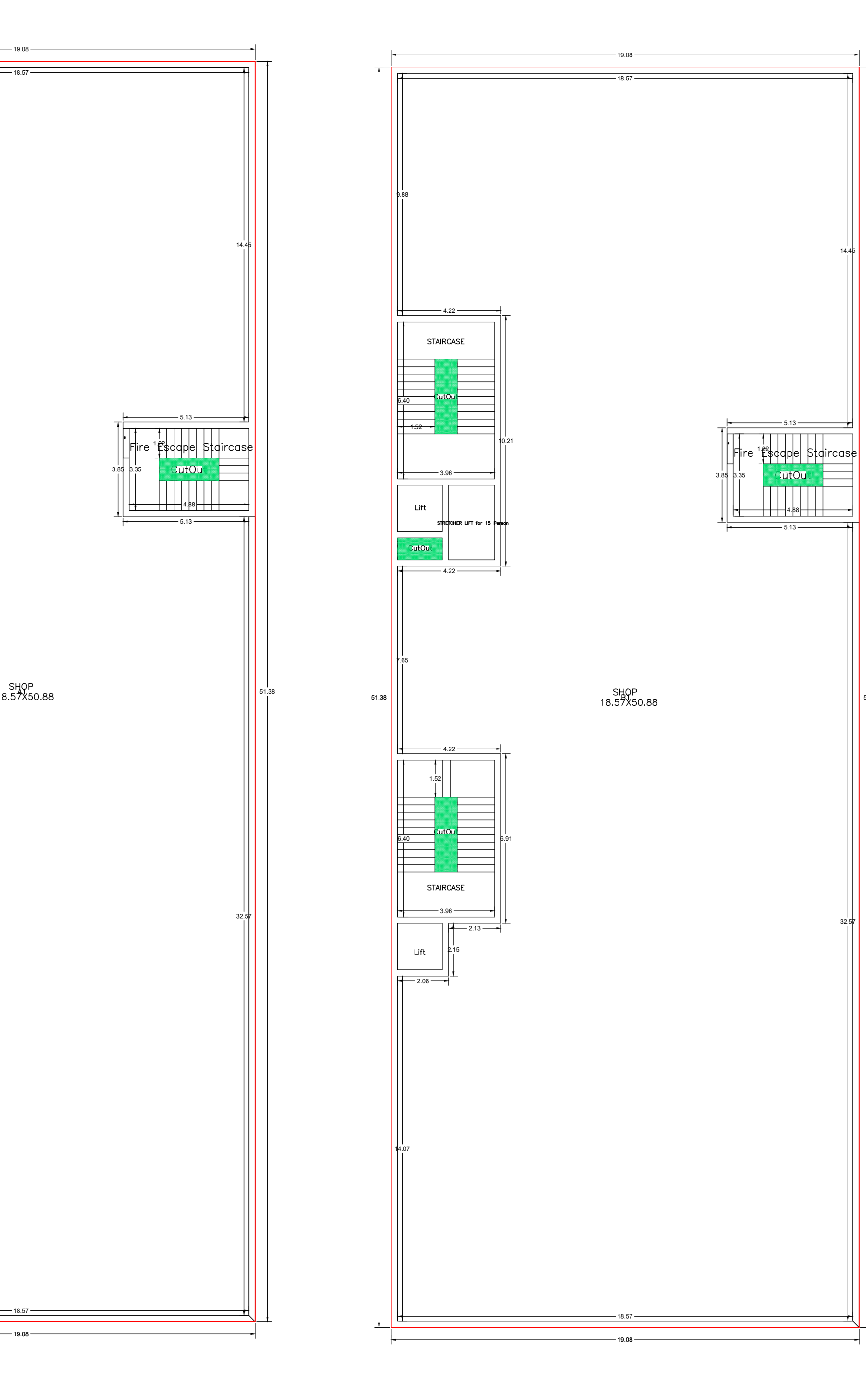
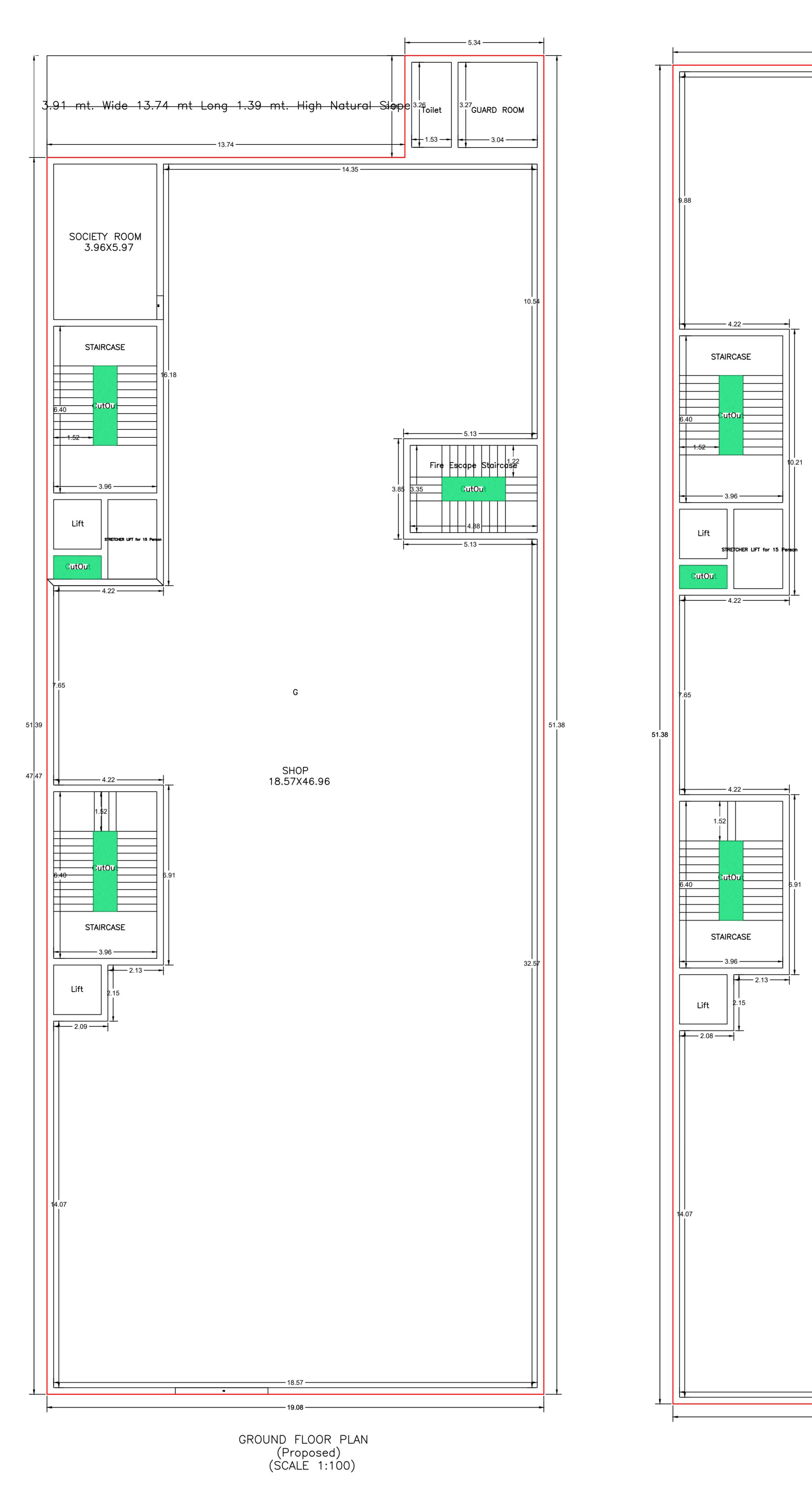
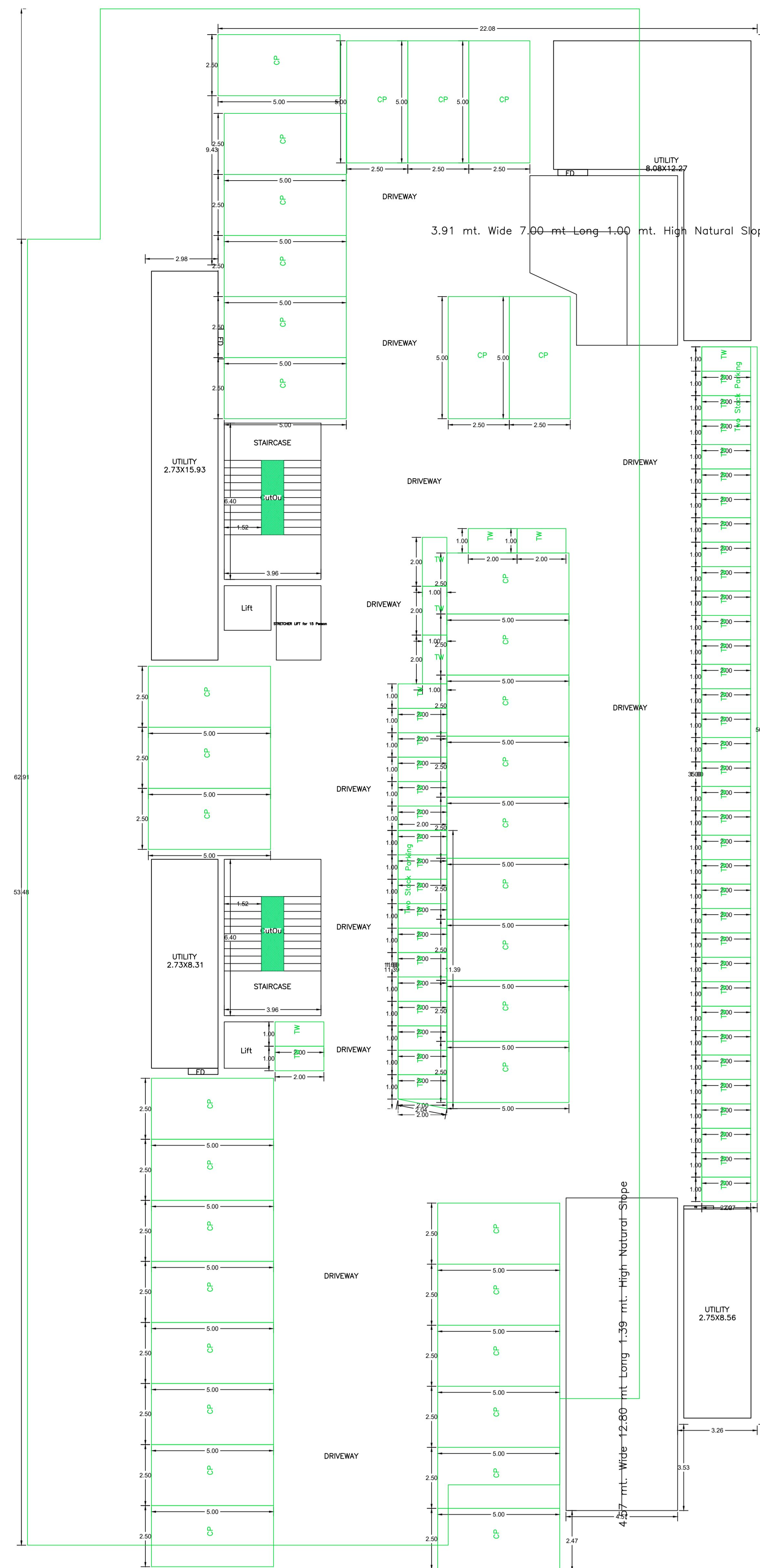

FAR & Tenement Details (Table 4c-1)

Building Type	No. of Storeys	Open Area (Sq. Mts)	Floor Area (Sq. Mts)	Total Floor Area (Sq. Mts)	Deductions (Area in Sq. Mts)					Proposed FAR Area (Sq. Mts)	Add. FAR Area (Sq. Mts)	Total FAR Area (Sq. Mts)	Total FAR Area (Sq. Mts)	Total FAR Area (Sq. Mts)	
					LR	LR	LR	LR	LR						
1	1	1803.23	72.08	7813.32	278.27	32.48	3.47	117.62	14.98	128.81	304.84	41.11	580.22	580.22	27
Total	1	1803.23	72.08	7813.32	278.27	32.48	3.47	117.62	14.98	128.81	304.84	41.11	580.22	580.22	27

Building Use/Subuse Details

Building Name	Building Subuse	Floor Name	Floor Subuse	FAR Name	FAR Subuse	FAR Area (Sq. Mts)	FAR Rate	FAR Value	
A/11	Commercial	Res/Comm-Bldg	Multistorey	1st Floor	Commercial	1803.23	0.00	0.00	0.00
				2nd Floor	Commercial	72.08	0.00	0.00	0.00
				3rd Floor	Commercial	72.08	0.00	0.00	0.00
				4th Floor	Commercial	72.08	0.00	0.00	0.00
				5th Floor	Commercial	72.08	0.00	0.00	0.00
				6th Floor	Commercial	72.08	0.00	0.00	0.00
				7th Floor	Commercial	72.08	0.00	0.00	0.00
				8th Floor	Commercial	72.08	0.00	0.00	0.00
				9th Floor	Commercial	72.08	0.00	0.00	0.00
				10th Floor	Commercial	72.08	0.00	0.00	0.00
				11th Floor	Commercial	72.08	0.00	0.00	0.00
				12th Floor	Commercial	72.08	0.00	0.00	0.00

Required Parking (Table 7a)

Building Name	Type	Sub Use	Area (Sq. Mts)	Units	Car	Two Wheeler	Auto Rickshaw	Other
A/11	Commercial	Shop	18.57x50.88	1	1	1	1	1
					1	1	1	1
					1	1	1	1
Total				1	1	1	1	

Parking Check (Table 7b)

Vehicle Type	No.	Area	Rate	Value
Car	1	55	627.06	627.06
Two Wheeler	1	11	132.00	132.00
Auto Rickshaw	1	3	37.50	37.50
Other	1	1	11.25	11.25
Total	4	70	807.81	807.81

UTILISLA Table for Building A (A1)

FLOOR	Name	UTILISLA Type	Utilisla Area	Cover Area	No. of Units	No. of Tenement
1st FLOOR	A1	SHOP	650.00	867.75	1	1
	B1	SHOP	650.00	867.75	1	1
2nd FLOOR	F1	FLAT	110.00	150.00	10	10
	F2	FLAT	110.00	150.00	10	10
	F3	FLAT	110.00	150.00	10	10
	F4	FLAT	110.00	150.00	10	10
3rd FLOOR	G1	FLAT	110.00	150.00	10	10
	G2	FLAT	110.00	150.00	10	10
	G3	FLAT	110.00	150.00	10	10
	G4	FLAT	110.00	150.00	10	10
4th FLOOR	H1	FLAT	110.00	150.00	10	10
	H2	FLAT	110.00	150.00	10	10
5th FLOOR	I1	FLAT	110.00	150.00	10	10
	I2	FLAT	110.00	150.00	10	10
6th FLOOR	J1	FLAT	110.00	150.00	10	10
	J2	FLAT	110.00	150.00	10	10
7th FLOOR	K1	FLAT	110.00	150.00	10	10
	K2	FLAT	110.00	150.00	10	10
8th FLOOR	L1	FLAT	110.00	150.00	10	10
	L2	FLAT	110.00	150.00	10	10
9th FLOOR	M1	FLAT	110.00	150.00	10	10
	M2	FLAT	110.00	150.00	10	10
10th FLOOR	N1	FLAT	110.00	150.00	10	10
	N2	FLAT	110.00	150.00	10	10
11th FLOOR	O1	FLAT	110.00	150.00	10	10
	O2	FLAT	110.00	150.00	10	10
12th FLOOR	P1	FLAT	110.00	150.00	10	10
	P2	FLAT	110.00	150.00	10	10

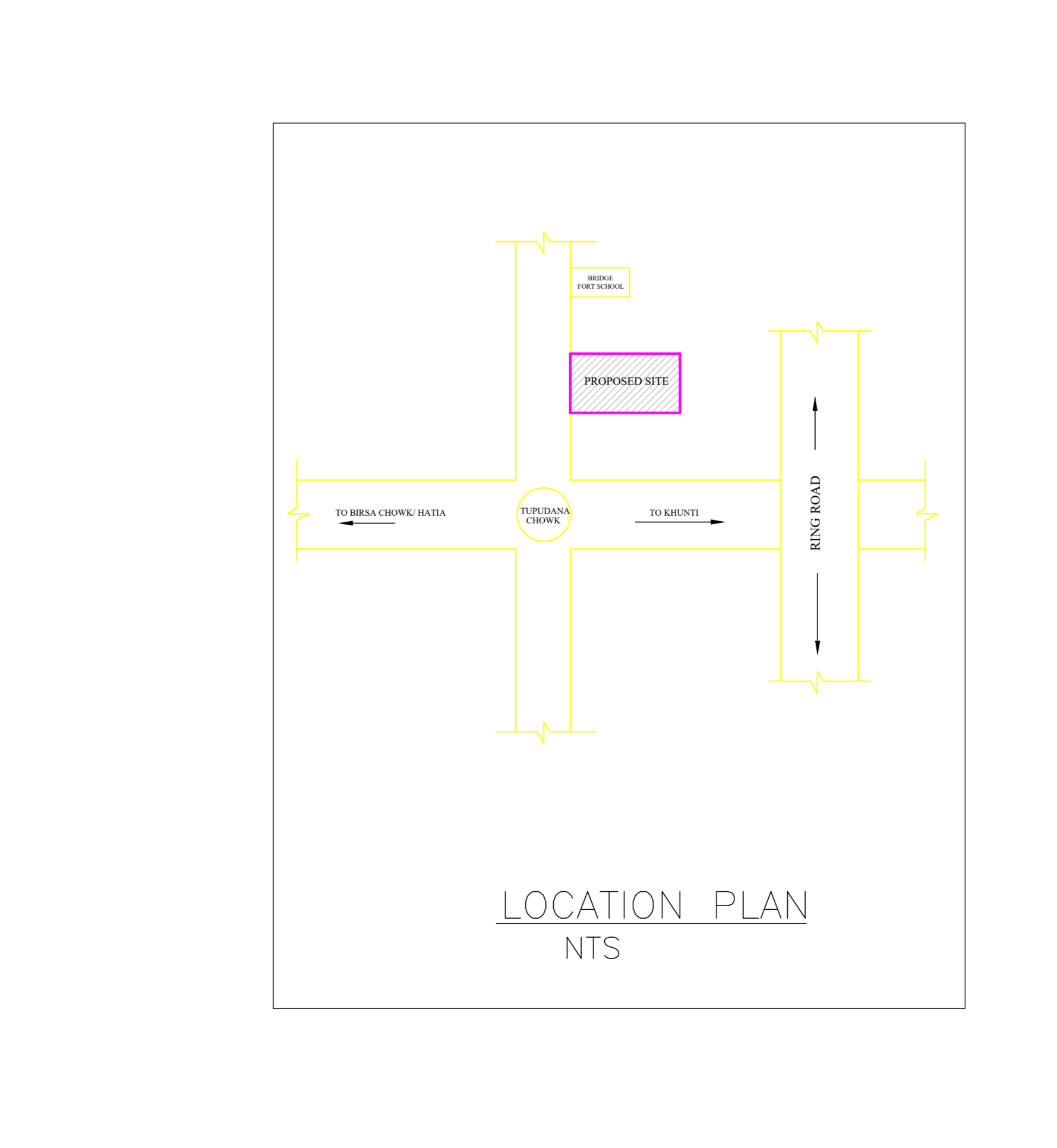
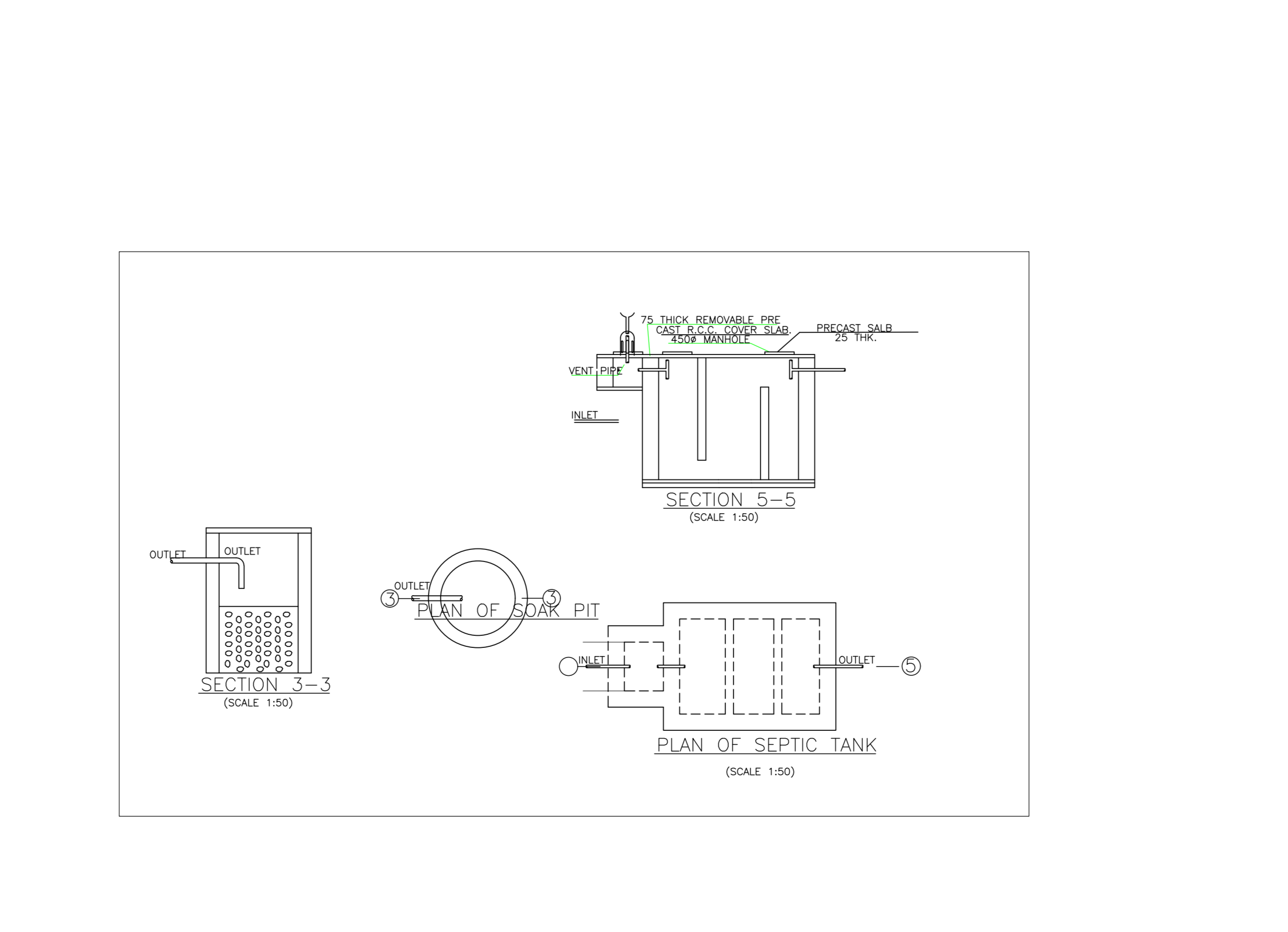
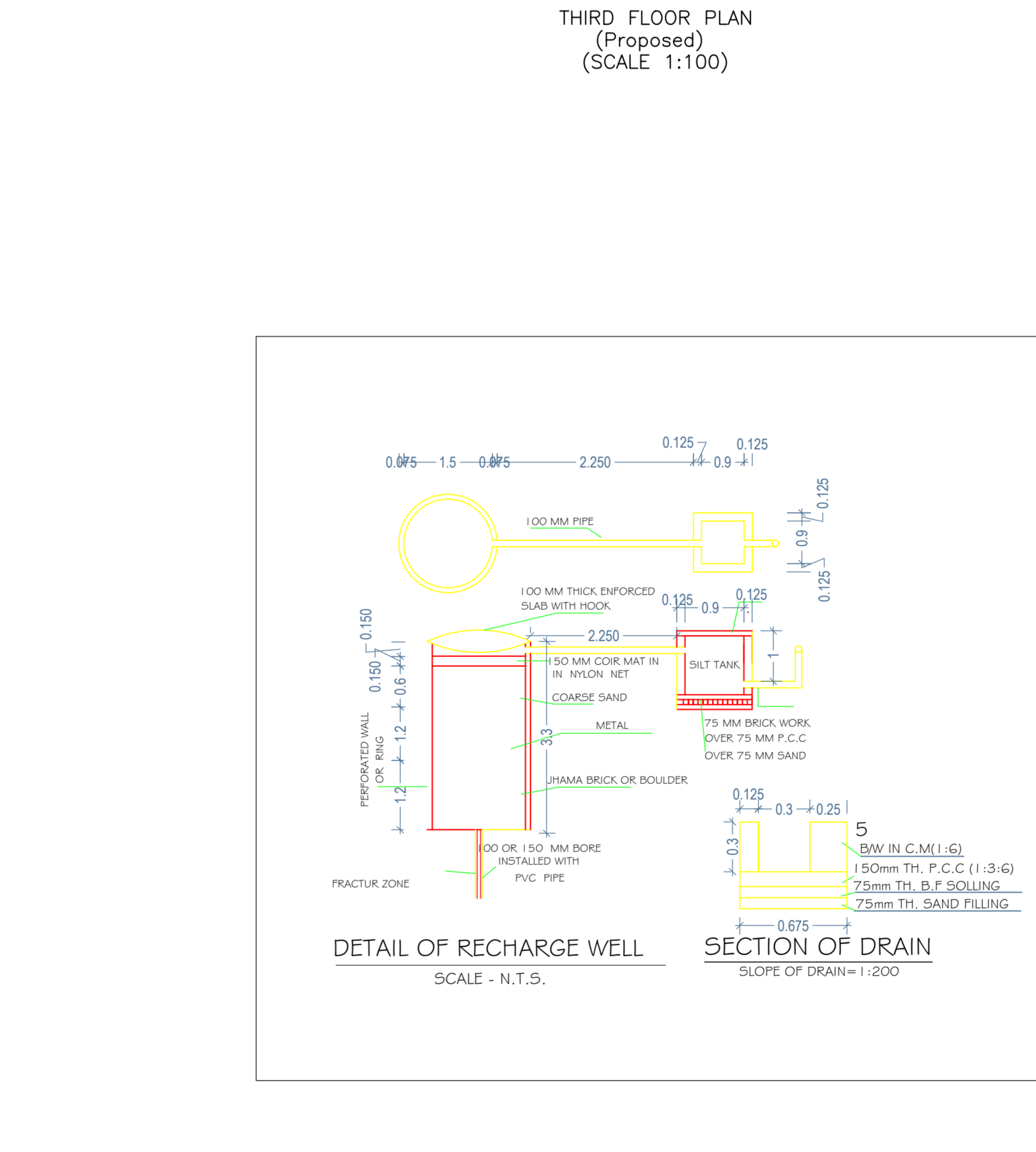
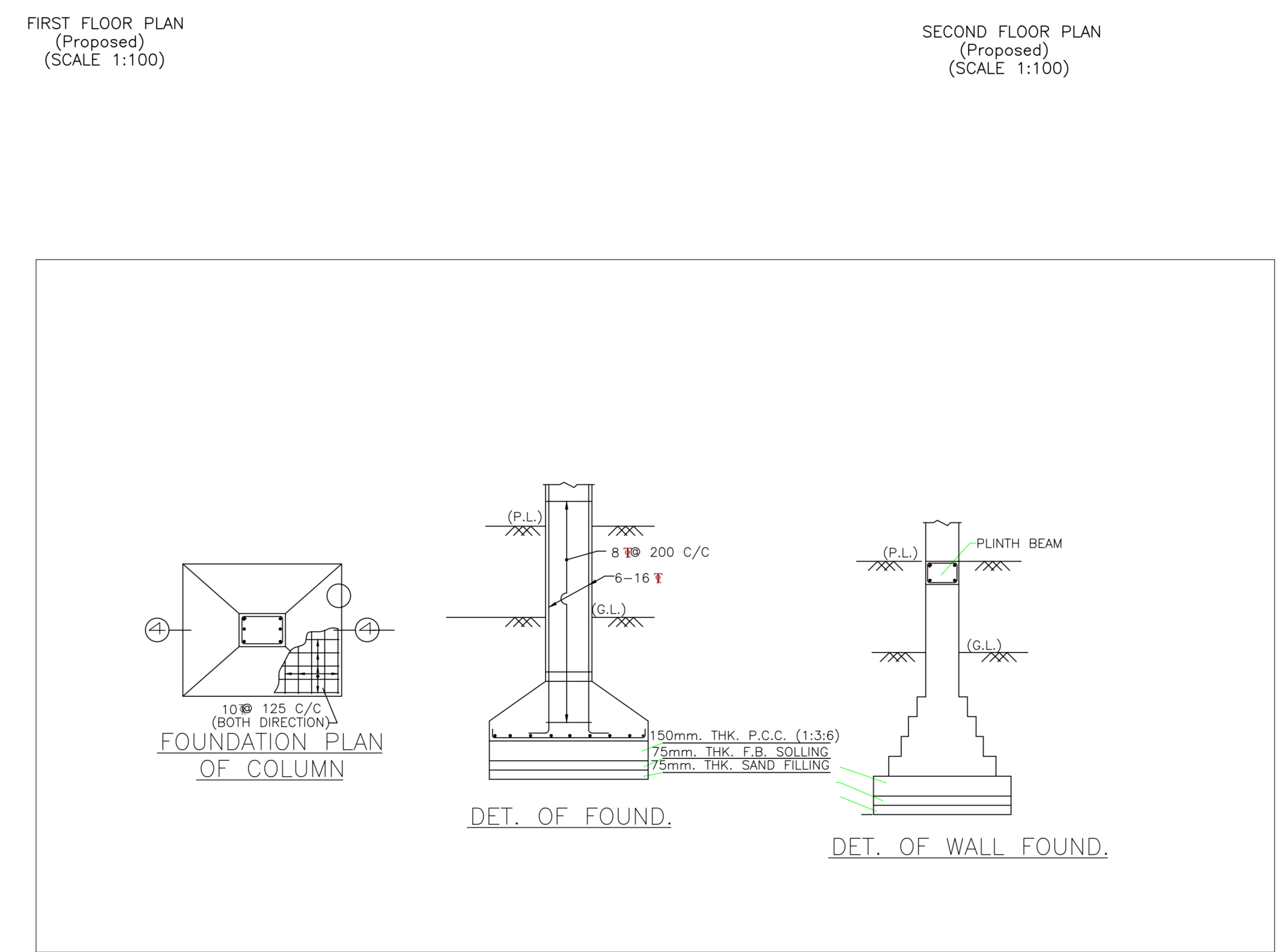
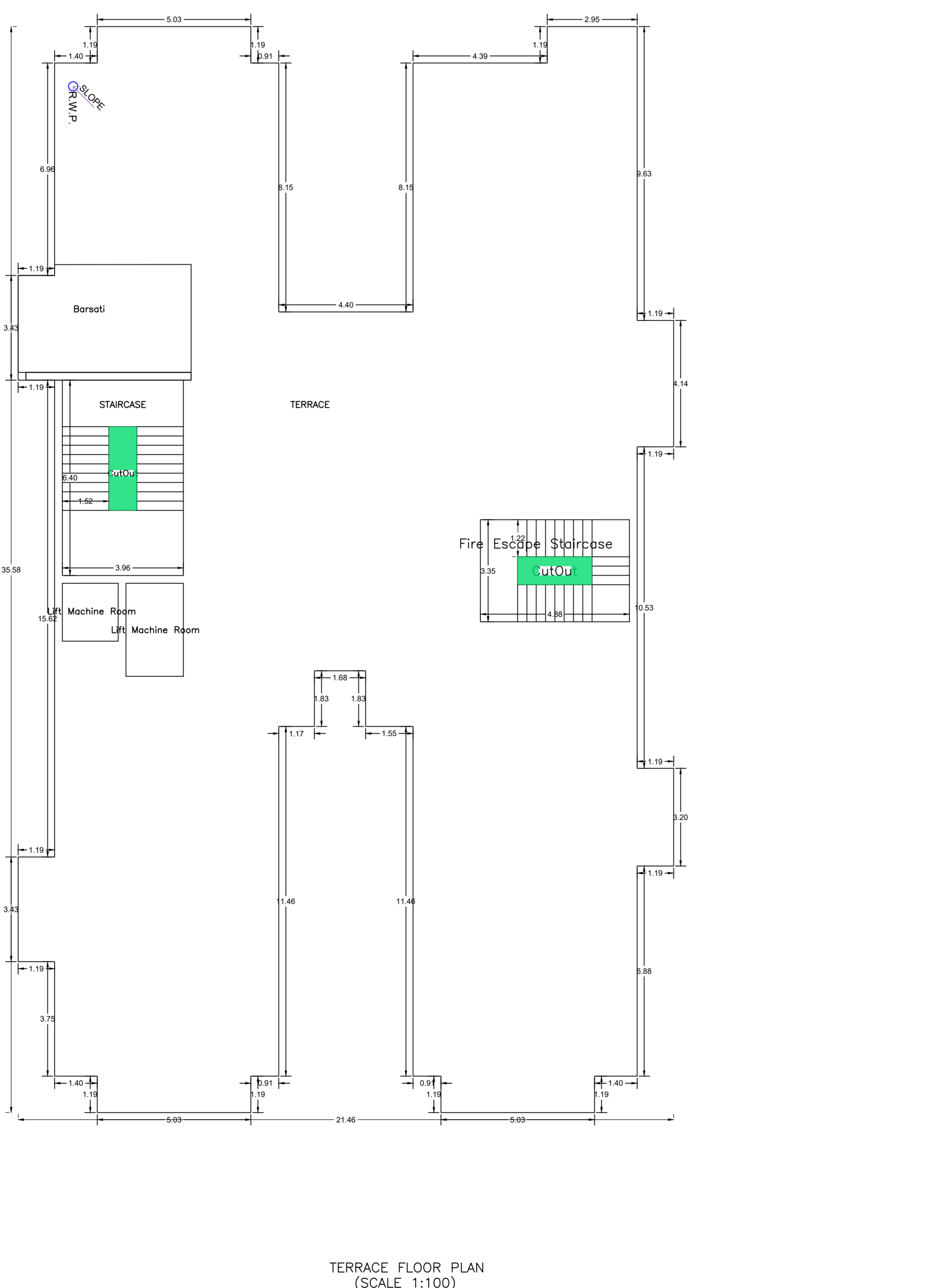
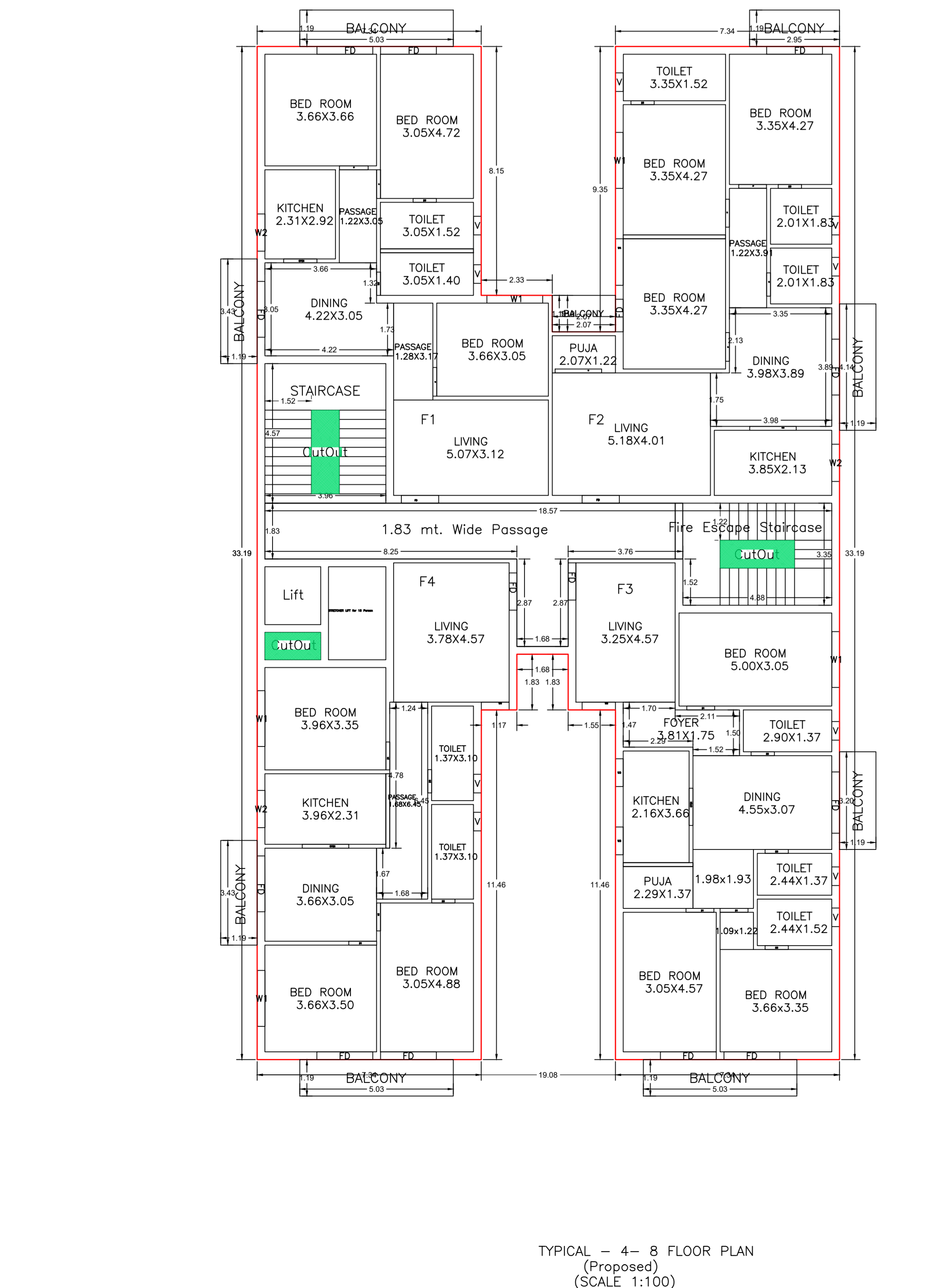

DATE AND SIGNATURE	STRUCTURAL ENGINEER AND SIGNATURE	BUILDER NAME AND SIGNATURE	DIGITAL SIGNATURE
ATUL BAWA	RMC/SP/16/03/0004		