

Proposal Basic Information

Proposal No.	RVCSP04M032024A12
Owner Name	ANAPURVA DEV AND DHEE PRAGATI CIVILS PVTY
Plot No.	2524
Plot No.	1561/561/1562/1663
Usage Name	Residential
Use	Residential
Sub Use	Residential Building

Building -BLOCK B (BUILDING)

Floor Name	Total Usable Area (Sq.M)	Existing Area (Sq.M)	Proposed Area (Sq.M)	Deletion/Increase (Sq.M)	Existing FAR (Sq.M)	Total FAR (Sq.M)	FAR Constraint (Sq.M)	Floor No.
Ground	388.8	388.8	0.0	0.0	388.8	388.8	388.8	04
1st Floor	388.8	388.8	0.0	0.0	388.8	388.8	388.8	04
2nd Floor	388.8	388.8	0.0	0.0	388.8	388.8	388.8	04
3rd Floor	388.8	388.8	0.0	0.0	388.8	388.8	388.8	04
4th Floor	388.8	388.8	0.0	0.0	388.8	388.8	388.8	04
Terrace	0.0	0.0	0.0	0.0	0.0	0.0	0.0	00
Total	1555.2	1555.2	0.0	0.0	1555.2	1555.2	1555.2	20

SCHEDULE OF DOOR:

BUILDING NAME	NAME	LENGTH	HEIGHT	NO.
BLOCK-B BUILDING	04	1.75	2.10	30
BLOCK-B BUILDING	03	0.75	2.10	30
BLOCK-B BUILDING	02	0.90	2.10	30
BLOCK-B BUILDING	01	0.90	2.10	30
BLOCK-B BUILDING	01	0.90	2.10	30
BLOCK-B BUILDING	01	0.90	2.10	30
BLOCK-B BUILDING	01	0.90	2.10	30
BLOCK-B BUILDING	01	0.90	2.10	30
BLOCK-B BUILDING	01	0.90	2.10	30
BLOCK-B BUILDING	01	0.90	2.10	30

SCHEDULE OF WINDOW/VENTILATION:

BUILDING NAME	NAME	LENGTH	HEIGHT	NO.
BLOCK-B BUILDING	04	1.75	2.10	30
BLOCK-B BUILDING	03	0.75	2.10	30
BLOCK-B BUILDING	02	0.90	2.10	30
BLOCK-B BUILDING	01	0.90	2.10	30
BLOCK-B BUILDING	01	0.90	2.10	30
BLOCK-B BUILDING	01	0.90	2.10	30
BLOCK-B BUILDING	01	0.90	2.10	30
BLOCK-B BUILDING	01	0.90	2.10	30
BLOCK-B BUILDING	01	0.90	2.10	30
BLOCK-B BUILDING	01	0.90	2.10	30

Balcony Calculations Table

ROOM	SIZE	AREA	TOTAL AREA
TYPICAL 1,2,3-4 FLOOR	1.2X3.8X1.1X4	17.14	284.9
BASE	1.5X7.7X1.1X4	57.16	
	1.5X3.8X1.1X4	24.58	
	1.5X3.8X1.1X4	17.14	
	1.5X3.8X1.1X4	24.58	
	1.5X3.8X1.1X4	17.14	
	1.5X3.8X1.1X4	24.58	
	1.5X3.8X1.1X4	17.14	
Total	1.5X3.8X1.1X4	284.9	

UnRBUA Table for Building -BLOCK B (BUILDING)

FLOOR	Name	UnRBUA Type	UnRBUA Area	Capex Area	No. of Units	PLT. Type
GROUND FLOOR PLAN	FLAT-101	FLAT	18.5	18.5	1	4
	FLAT-102	FLAT	18.5	18.5	1	4
	FLAT-103	FLAT	18.5	18.5	1	4
	FLAT-104	FLAT	18.5	18.5	1	4
TYPICAL 1, 2, 3-4 FLOOR PLAN	FLAT-201	FLAT	18.57	18.57	1	16
	FLAT-202	FLAT	18.57	18.57	1	16
	FLAT-203	FLAT	18.57	18.57	1	16
	FLAT-204	FLAT	18.57	18.57	1	16
Total			155.2	155.2	161	20

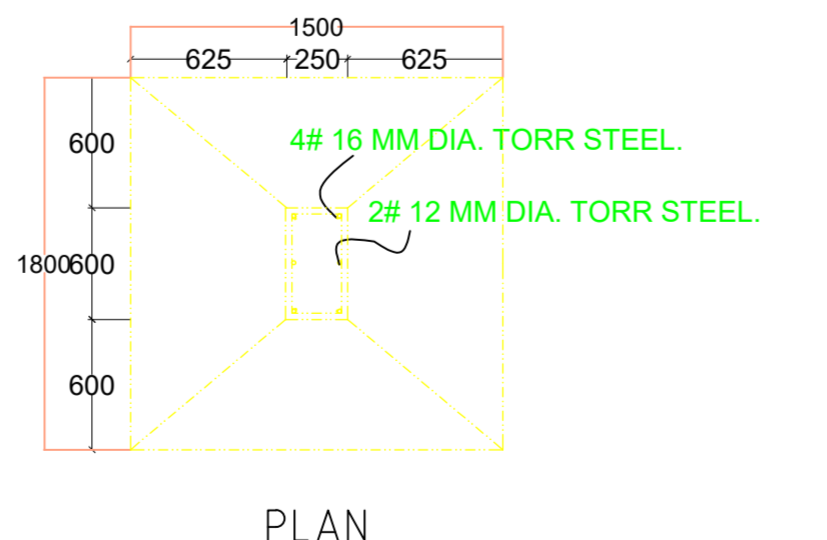
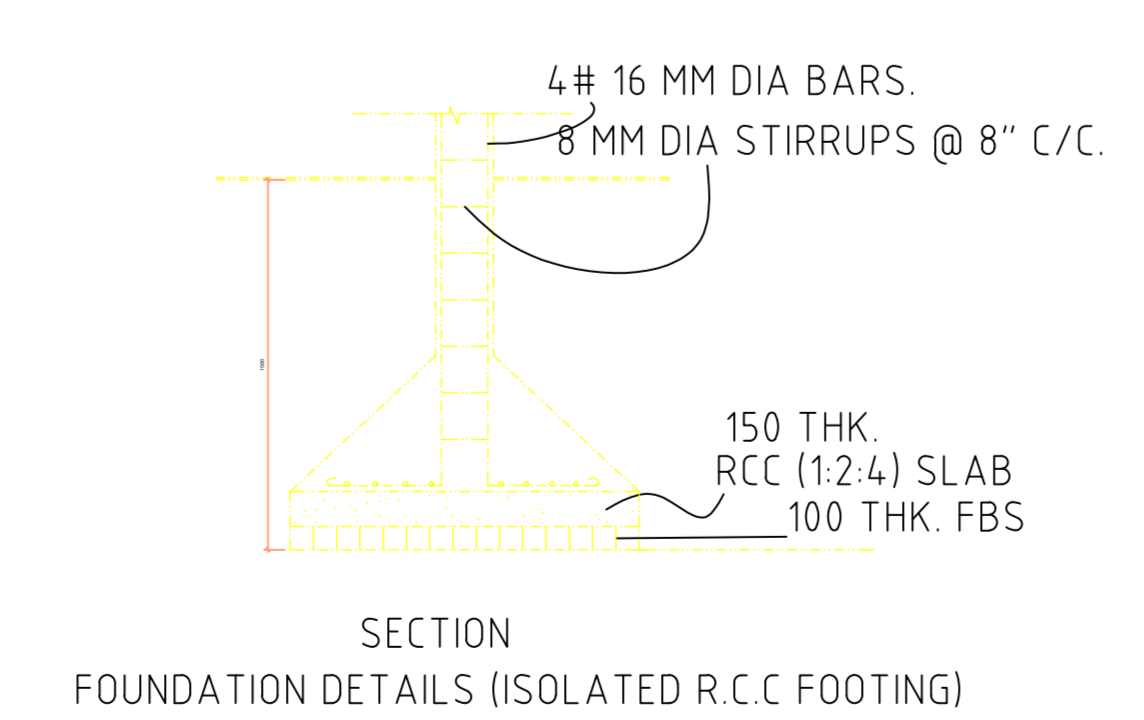
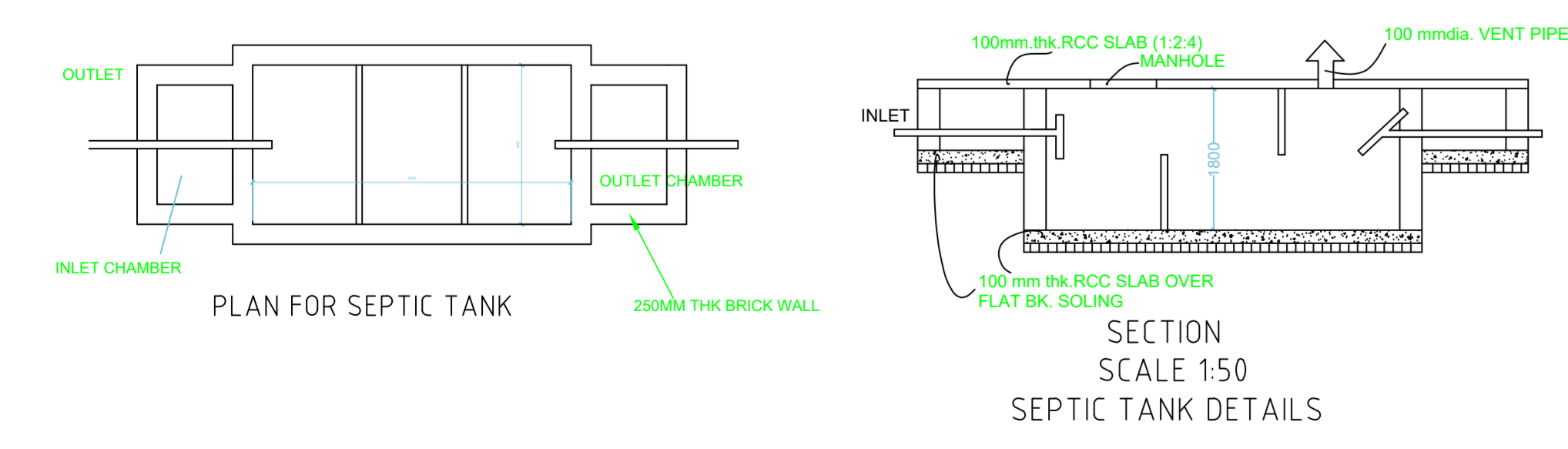
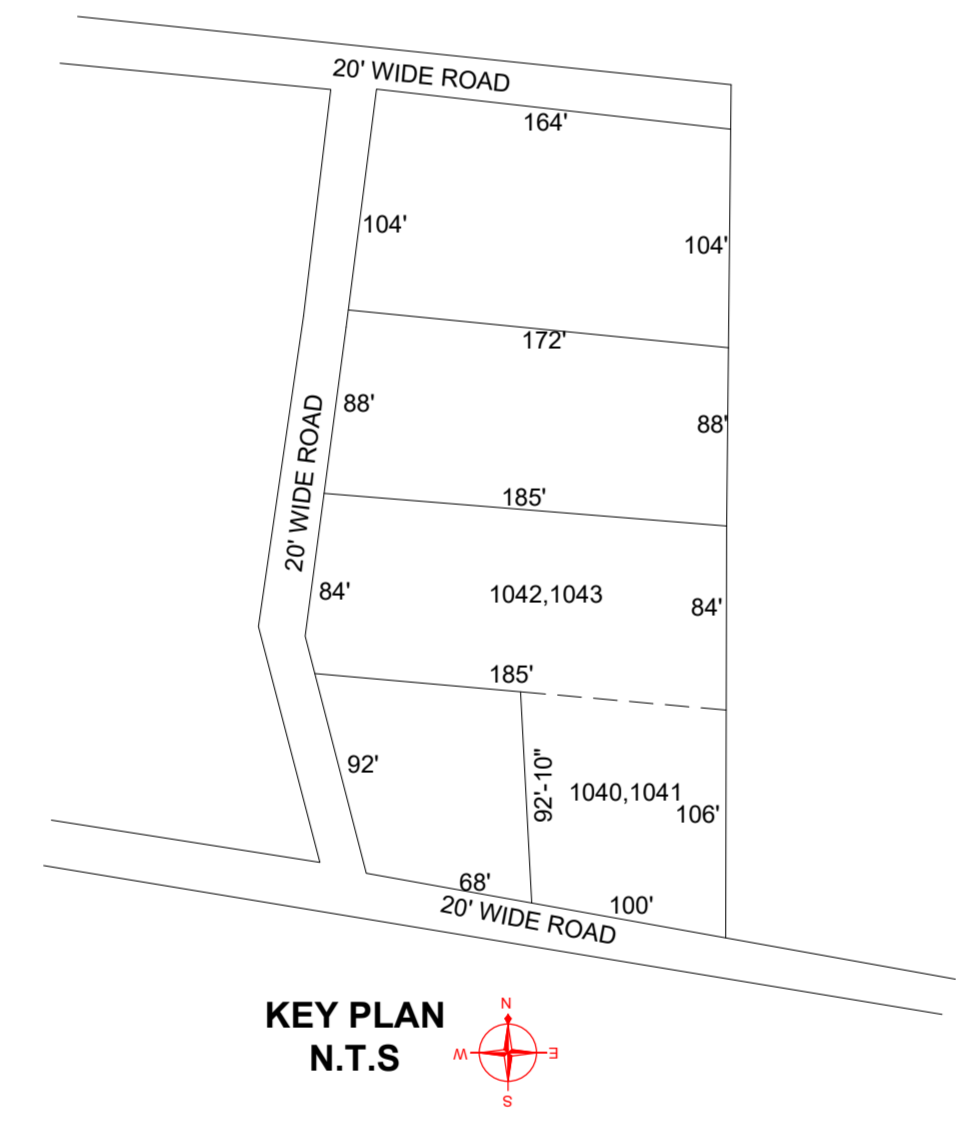
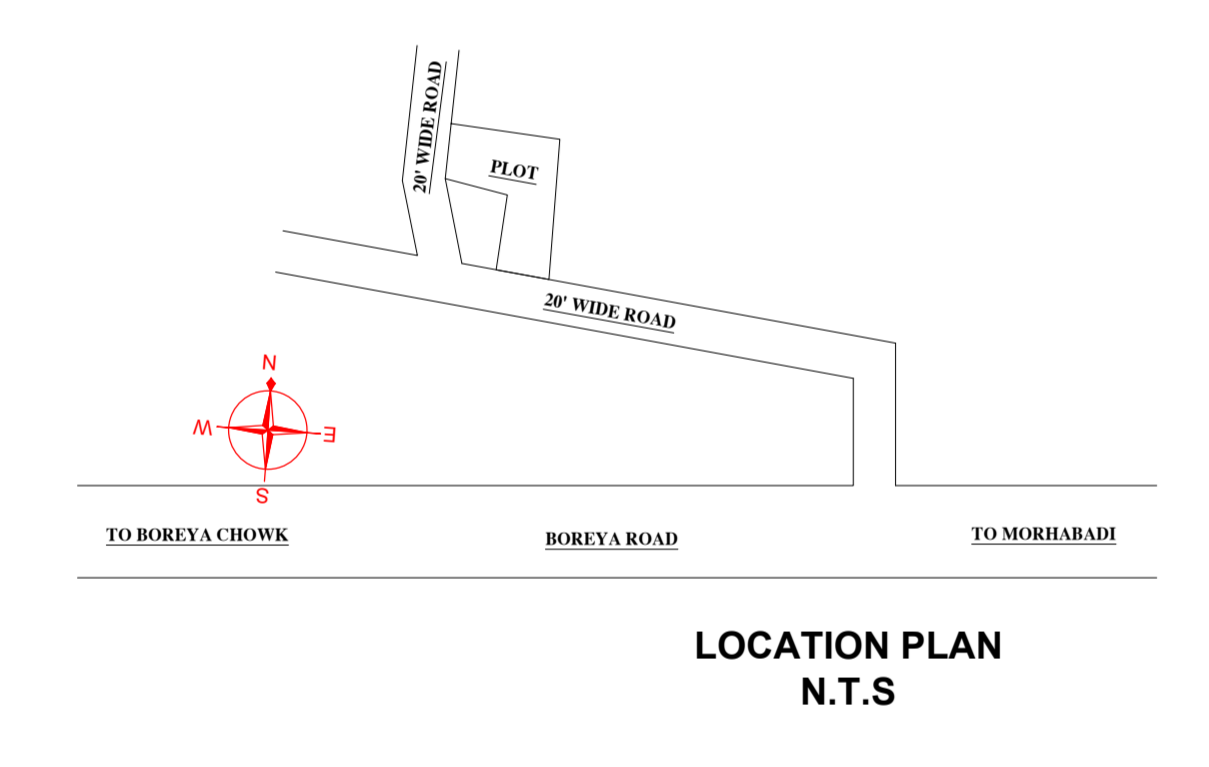
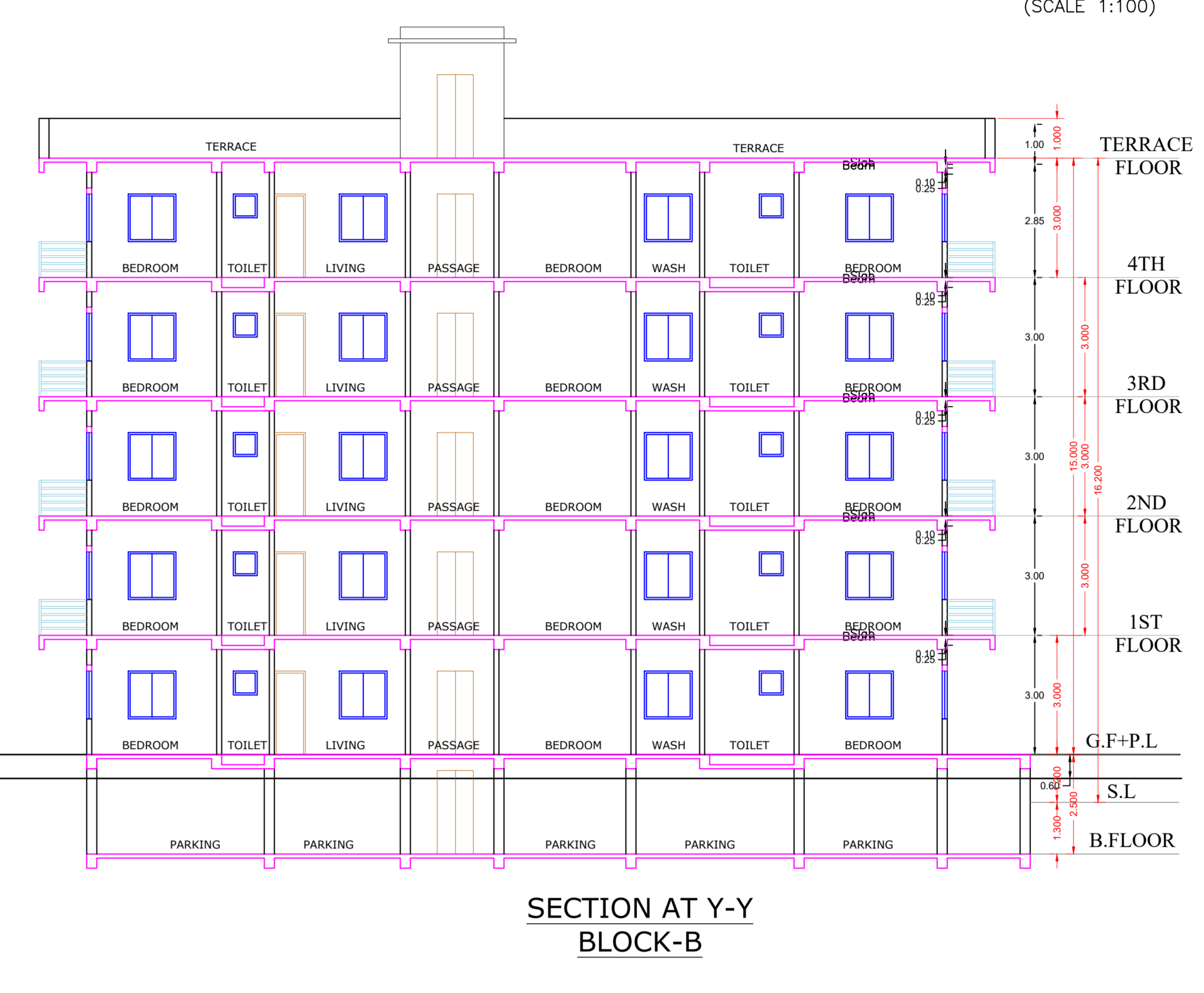
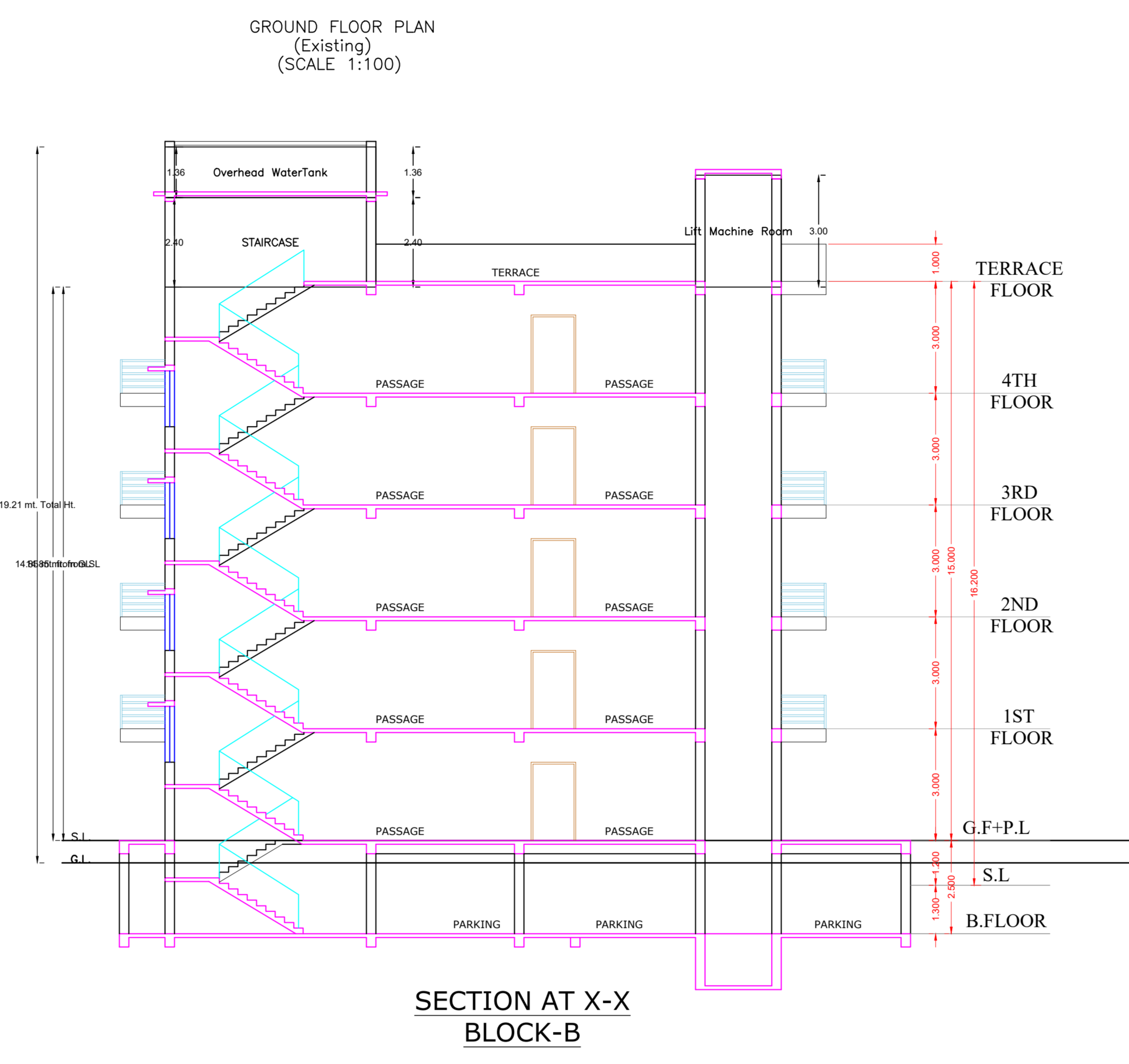
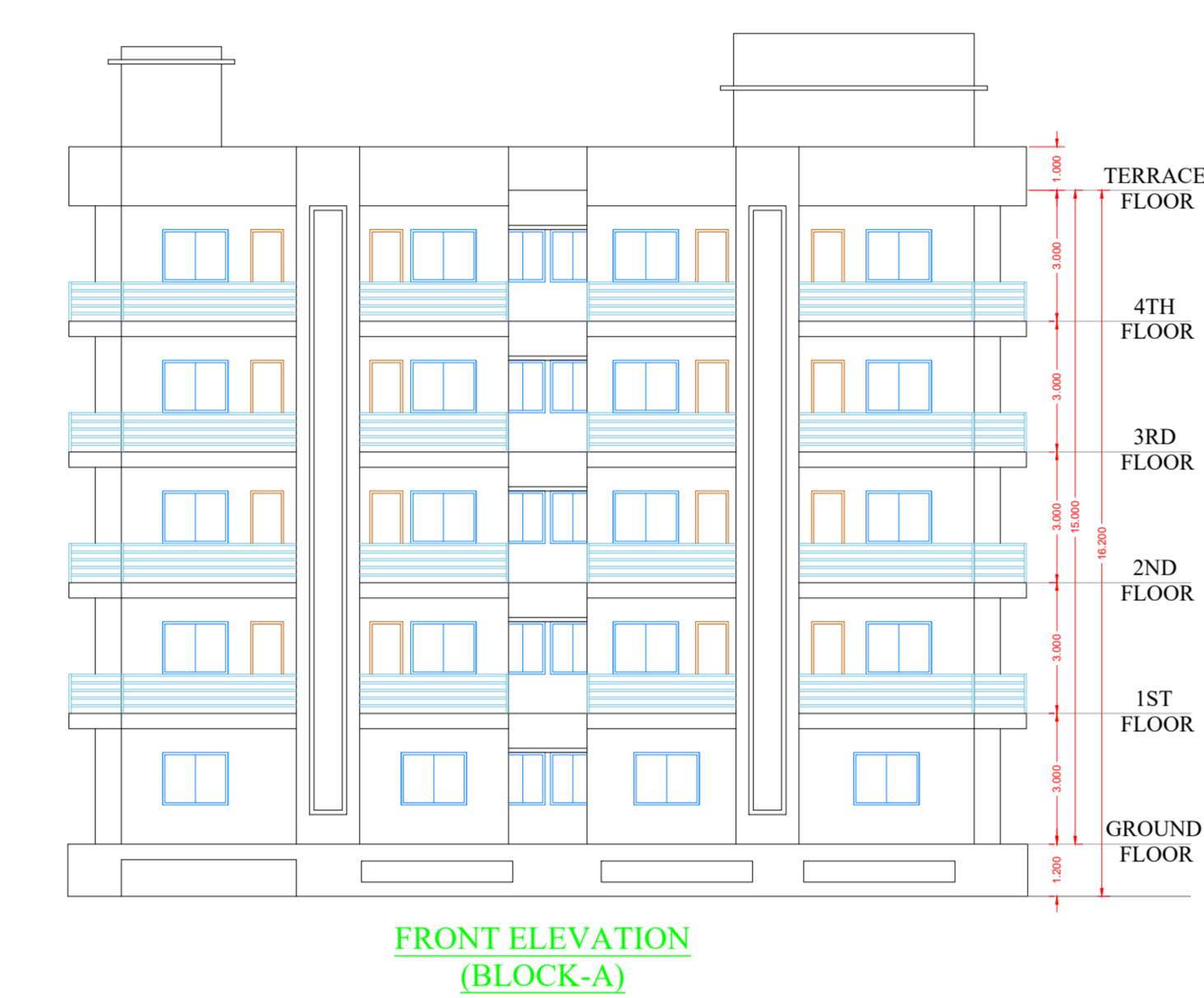

BUILDING IS AS PER IS CODE 189-1884-B 1993 TO MAKE THE SAME EARTH QUAKE RESISTANT.

